

Instruction set 220805.3
Set-instructie
Einbauanleitung
Jeu d'instructions

First issue 31-08-11
Eerste uitgave
Erste Ausgabe
Première édition

DC/name D13 006 / RD
DC/naam
DC/name
DC/nom

Assembly manual 221941.3
Montagehandleiding
Montageanleitung
Manuel de montage

Release/name 04-03-13 / RD
Vrijgifte/naam
Freigabe/name
Autorisation/nom

Make Volkswagen
Merk
Marke
Marque

Type Tiguan 1.4 TSi 110/118kW
Type
Typ
Type

Cubic capacity 1390 cc
Cilinderinhoud
Hubraum
Cilindré

Engine type CAVA / CAVD
Motortype
Motortyp
Type moteur









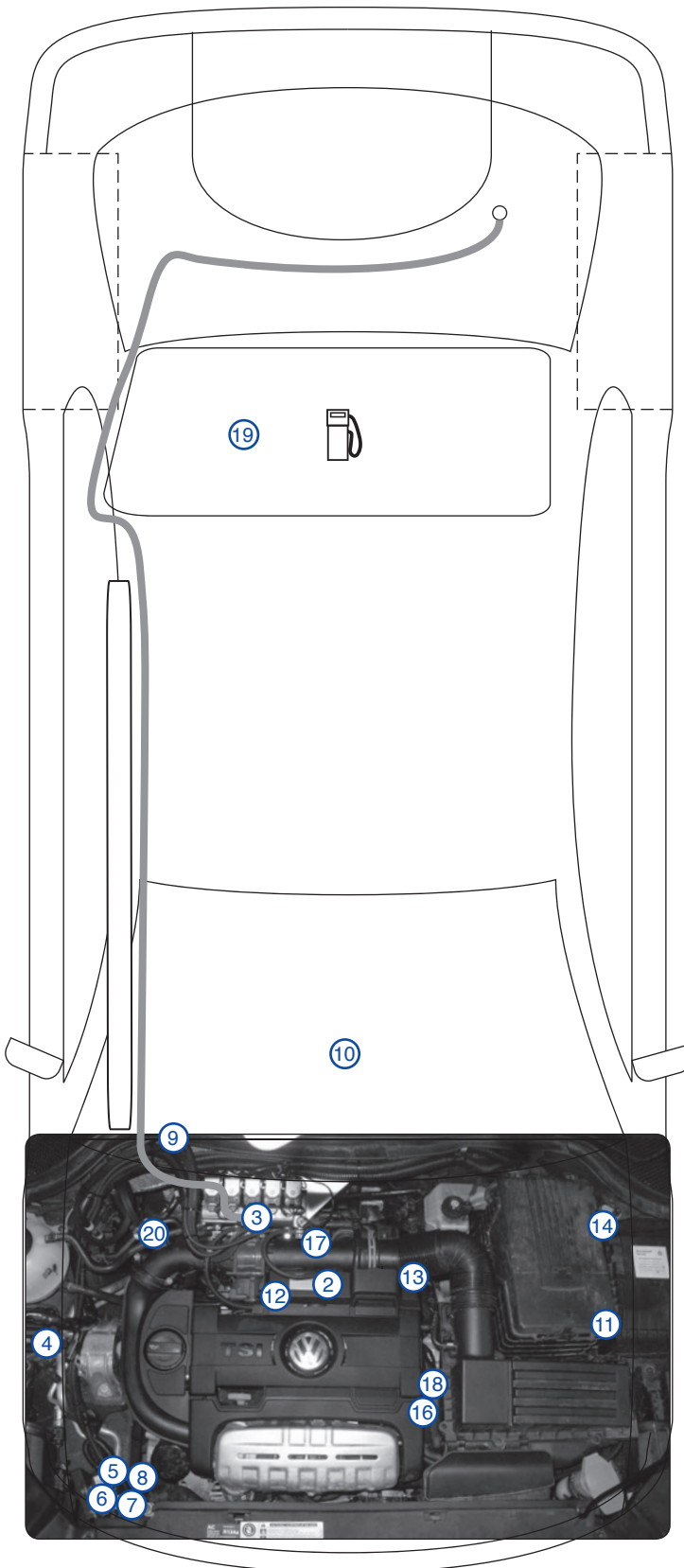











Transmission Manual / DSG
Transmissie
Getriebeausführung
Transmission
Handgeschakeld / DSG-getriebe
Schaltgetriebe / DSG
Manuelle / DSG

































Model year 2008 -
Modeljaar
Modeljahr
Anné modelé

Tank Situation T1 SUV
Tanksituaties
Tankinformation
Situations réservoirs
SUV
SUV
SUV

Sunken installation 70 ltr. Ring tank
Verzonken inbouw 70 ltr. Ringtank
Versenkerter einbau 70 ltr. Ringtank
Réservoir encastré 70 ltr. Réservoir torique



- ①  **Manifold**
 Spruitstuk
 Ansaugkrummer
 Collecteur
- ②  **High Pressure pump**
 Hoge druk pomp
 Hohe druckpumpe
 Pompe haute pression
- ③  **Fuel Selector Unit LPdi (FSU)**
 Fuel Selector Unit LPdi
 Fuel Selector Unit LPdi
 Fuel Selector Unit LPdi
- ④  **LPE-7 regulator**
 LPE-7 regelenheid
 LPE-7 steuerg r t
 LPE-7 unit  de r glage
- ⑤  **Resistor**
 Weerstand
 Widerstand
 R sistance
- ⑥  **Interface box LPdi**
 Interface LPdi
 Interface LPdi
 Interface LPdi
- ⑦  **Main relay**
 Hoofdreleis
 Haubtreleis
 Relais principal
- ⑧  **Fuse holder**
 Zekeringhouder
 Sicherungshalter
 Porte-fusible
- ⑨  **Carry through**
 Doorvoeren
 Durch f hren
 Passez
- ⑩  **Fuel switch**
 Brandstofkeuze-schakelaar
 Kraftstoffwahlschalter
 S lecteur de carburant
- ⑪  **Battery+**
 Accu+
 Batterie+
 +Batterie
- ⑫  **Ground engine**
 Massa motorblok
 Masse motorblock
 Masse bloc moteur
- ⑬  **Petrol pressure sensor high**
 Benzine hoge druk sensor
 Benzin hohe druck sensor
 Capteur d'essence haute pression
- ⑭  **CAN-bus**
 CAN bus
 CAN bus
 CAN bus
- ⑮  **LPG injector connection**
 Aansluiting LPG-injector
 Anschlu  der LPdi-injector
 Raccordement des injecteur GPL
- ⑯  **Temperature sensor**
 Temperatuur sensor
 Temperatur sensor
 Capteur de temp rature
- ⑰  **Canister purge valve**
 Canister klep
 Canister ventil
 Boite de la vanne
- ⑱  **Petrol injector interrupt**
 Onderbreking benzine-injector
 Unterbrechung der benzineinspritzventil
 Interruption des injecteur d'essence
- ⑲  **Engine running**
 Motorloop
 Motorlauf
 Moteur en marche
- ⑳  **Canister connection**
 Canister aansluiting
 Anschlu  der canister
 Raccordement des bo te de la vanne

 Fit/Assemble Monteren/assembleren Montieren/zusammensetzen Montez/assemblez	 Fuel Selector Unit LPdi (FSU) Fuel Selector Unit LPdi Fuel Selector Unit LPdi Fuel Selector Unit LPdi	 Won't be used Wordt niet gebruikt Nicht benötigt Non utilisés
 Disassemble Demontieren Demontieren Démontez	 LPE-7 regulator LPE-7 regeleenheid LPE-7 steuergerät LPE-7 unité de réglage	 In accordance with manual: Volgens handleiding Gemäß anleitung Suivant le manuel
 Drill Boren Bohren Percer	 Fuses Zekeringenhouder Sicherungshalter Fusibles	 High Pressure pump Hoge druk pomp Hohe druckpumpe Pompe haute pression
 Mark Markeren Markieren Marquer	 Main relay Hoofdrelais Hauptrelais Relais principal	 Carry through Doorvoeren Durch führen Passez
 Modify Aanpassen Anpassen Adaptez	 Interface box LPdi Interface LPdi Interface LPdi Interface LPdi	 Wiring harness route Kabelboom Kabelbaum Faisceau du câbles
 Glue/Stick/Cement/Use Loctite Lijmen/Plakken/Kitten/Loctite gebruiken Leimen/Aufkleben/Kitten/Loctite benutzen Coller//afficher/Mastiquer/Faire usage deLoctite	 Fuel switch Brandstofkeuze-schakelaar Kraftstoffwahlschalter Sélecteur de carburant	 Canister connection Canister aansluiting Anschluß der canister Raccordement des boîte de la vanne
 Torque Moment Moment Dynamométrique	 Battery+ Accu+ Batterie+ +Batterie	 Replace Vervangen Ersetzen Remplacer
 Prevent leakage + engine noise Voorkom lekkage en motorlawaai Verhinder wassereintritt und motorenlärm éviter la pénétration d'eau et le bruit du moteur	 Ground engine Massa motorblok Masse motorblock Masse bloc moteur	 If not properly attached Indien niet goed vast Wenn lose sitzt Avec de la colle
 Solder and insulate Solderen en isoleren Anlöten und isolieren Souder et isoler	 Engine running Motorloop Motorlauf Moteur en marche	 Hose route Leidingloop Leitungsverlauf Route de conduites
 Insulate isoleren abisolieren Couper et isoler	 Petrol injector interrupt Onderbreking benzine-injector Unterbrechung der benzineinspritzventil Interruption des injecteur d'essence	 Do not drill in the wires/hoses Niet in de bedrading/slangen boren Nicht in die verkablung/schläuche bohren Ne pas percer dans les câblages/flexibles
 Screw Vastschroeven Schrauben Ecrou	 Resistor Weerstand Widerstand Résistance	 Temperature sensor Temperatuur sensor Temperatur sensor Capteur de température

CAN
 CAN bus
 CAN bus
 CAN bus

 **Canister purge valve**
 Canister klep
 Canister ventil
 Boîte de la vanne

 **Petrol pressure sensor high**
 Benzine hoge druk sensor
 Benzin hohe druck sensor
 Capteur d'essence haute pression

 **LPG injector connection**
 Aansluiting LPG-injector
 Anschluß der LPdi-injector
 Raccordement des injecteur GPL

 **Manifold**
 Spruitstuk
 Ansaugkrummer
 Collecteur

 **Clean**
 Reinigen
 Reinigen
 Nettoyer

	EN	NL	DE	F
BN	brown	bruin	braun	brun
BU	blue	blauw	blau	bleu
BK	black	zwart	schwarz	noir
GN	green	groen	grün	vert
GY	grey	grijs	grau	gris
OR	orange	oranje	orange	orange
PK	pink	roze	rosa	rose
PU	purple	paars	lila	violet
RD	red	rood	rot	rouge
WH	white	wit	weiß	blanc
YE	yellow	geel	gelb	jaune

GUIDELINES BEFORE THE ASSEMBLY (ENGLISH)

- The assembly can only be performed by trained and appointed fitters of Vialle AFS.
 - Please check that you have the correct kit for the assembled vehicle.
 - These assembly instructions indicate only the specific information for this type of car, as mentioned in the cover sheet.
 - For further information, you must always consult the basic course of the LPdi systems.
 - Consult the workshop manual before components are disassembled
 - All instructions provided in this manual are from the perspective of the driver's position behind the steering wheel
 - Cylinder 1, as described in the connection of wiring harnesses is located on the distribution side of the engine!
 - Undo the earth cable from the battery before starting to build in the LPG installation (unless otherwise specified in the workshop instructions).
- Note: the memories of any radios and/or telephone may be wiped, the central door locking may engage and the alarm may go off. If necessary the battery may be connected temporarily
- Deburr the drilled holes, remove any chippings from the vehicle and treat the edges with an anti-rust agent
 - Lay the wiring harness such that it can't crack, it won't get damaged by heat sources, and it has enough distance from the ignition parts. Seal any open splits after the assembly of the wiring harness with silicon rubber to prevent noise and water leakage
 - The wires without connector can be clipped off at the right length, the red wire as short as possible. Please do not roll up the (eventual) excess length due to failures, but tidy them away using a "detour".
 - The electrical connections must be made with the delivered connectors or by soldering and finishing with a shrink sleeve.
 - Assemble the delivered fuses according to the electrical diagram.
 - The LPG installation should be built in accordance with the National Instructions for the fitting of a LPG Installation

Failure to comply with the instructions in this manual may result in a poor or inoperative gas installation or may cause a hazardous situation

The illustrations, technical information, data and text were correct at the time of printing. In spite of the care taken in the composition of this publication, no liability can be accepted on the grounds of any fault or error which might occur in this publication

Published by
Vialle Alternative Fuel Systems BV

RICHTLIJNEN VOOR INBOUW (NEDERLANDS)

- De inbouw mag alleen verricht worden door Vialle AFS getrainde en aangevozen installateurs.
- Controleer of u de juiste kit heeft voor het in te bouwen voertuig.
- Deze inbouw instructie vermeldt alleen de specifieke informatie voor dit type auto, zoals vermeld op het voorblad.
- Voor verdere informatie moet altijd de map basiscursus LPdi-systemen geraadpleegd worden.
- Raadpleeg het werkplaatshandboek voordat onderdelen worden gedemonteerd
- Alle richtingen aangegeven in deze handleiding zijn vanuit de positie van de chauffeur achter het stuurwiel
- Cilinder 1, zoals omschreven bij aansluitingen kabelbomen, bevindt zich aan de distributiezijde van de motor!
- Neem de massakabel van de accu los voor de aanvang van de inbouw van de LPG-installatie (tenzij anders vermeld in de werkplaatsinstructies). Let op: het geheugen van evt. radio en/of telefoon kan hierbij gewist worden, centrale portiervergrendeling kan op slot gaan en het alarm kan af gaan. Indien nodig kan de accu tijdelijk worden aangesloten
- Ontbraam de geboorde gaten, verwijder de eventuele spanen uit de auto, en behandel de randen met een anti-roestmiddel
- Leg de kabelboom zodanig dat deze niet kan doorschuren, en/of beschadigen door een hittebron, en/of te dicht bij ontstekingsdelen kan liggen. Openstaande spleten na montage van de kabelboom dichten met siliconrubber tegen lawaai en waterlekage
- De draden zonder connector op de juiste lengte afknippen, rode draad zo kort mogelijk. De (eventuele) overlength van de draden met connector niet oprollen in verband met storingen, maar met een 'omweg' wegwerken
- Elektrische verbindingen moeten gemaakt worden met de daarvoor bijgeleverde connectoren of d.m.v. solderen en afwerken met krimpkous.
- Monteer bijgeleverde zekeringen volgens elektrisch schema.
- De LPG-installatie dient ingebouwd te worden conform de geldende Rijksvoorschriften voor het aanbrengen van een LPG-installatie

Niet opvolgen van de instructies in deze handleiding kan resulteren in een slecht of niet werkende gasinstallatie of een gevaarlijke situatie opleveren

De afbeeldingen, technische informatie, gegevens en teksten waren correct ten tijde van de druk. Ondanks alle aan de samenstelling van deze uitgave bestede zorg, kan geen aansprakelijkheid worden aanvaard op grond van enige fout of vergissing die in deze uitgave zou kunnen voorkomen

Uitgegeven door
Vialle Alternative Fuel Systems BV

RICHTLINIEN BEVOR EINBAU (DEUTSCH)

- Der Einbau darf nur von Vialle AFS trainierten und angewiesenen Installateuren ausgeführt werden.
- Prüfen Sie ob Sie über den richtigen Satz für das ein zu bauen Fahrzeug verfügen.
- Diese Einbauanleitung gibt, wie auf dem Vorblatt erwähnt, nur die spezifische Information für diesen Autotyp an.
- Zu weiteren Informationen soll immer die Mappe Grundkurs LPdi-Systeme herangezogen werden.
- Alle für die Montage der Gasanlage betreffenden Komponenten gemäß Werkstatthandbuch ausbauen.
- Alle Abbildungen in der Einbauanleitung sind in Fahrtrichtung aus Sicht des Fahrers angegeben.
- Der 1. Zylinder befindet sich vorne (an der Seite des Riementriebs)!
- Bevor Einbau der Gasanlage, Minuspol der Fahrzeugbatterie abkleben (es sei auf eine andere Weise in dem Werkstatthandbuch erwähnt) Achtung: nach dem Abkleben der Fahrzeugbatterie wird ggf. der Speicher des Radios oder des Telefons gelöscht. Eine evtl. im Fahrzeug vorhandene Alarmanlage kann Alarm auslösen.
- Falls notwendig, kann die Batterie vorübergehend angeschlossen werden.
- Zum Einbau notwendige Bohrungen entgraten und mit Korrosionsschutzmittel behandeln. Ggf. vorhandene Metallspäne entfernen.
- Verlegen Sie den Kabelbaum auf eine Weise, sodass dieser nicht durchscheuern kann, und/oder von einer Hitzequelle beschädigt wird, und/oder zu nahe an den Zündungsteilen liegt. Offenstehende Spalten nach Einbau des Kabelbaums mit Silikonummi gegen Lärm und Wasserleckage abdichten.
- Die Kabel ohne Stecker entsprechend abschneiden, rotes Kabel so kurz wie möglich. (Eventuelle) Überlängen der Kabel mit Anschlussstecker wegen EMV-Störungen nicht aufwickeln sondern im Fahrzeug verlegen.
- Elektrische Verbindungen sollen mit den dazu gelieferten Stecker oder mittels anlöten und vollenden mit Schrumpfschlauch angefertigt werden.
- Mitgelieferte Sicherungen gemäß Schaltplan montieren.
- Die Autogasanlage muss gemäß den entsprechenden gesetzlichen Vorschriften eingebaut werden.

Bei Nichteinhaltung der beschriebenen Arbeitsanweisungen kann es zu Fehlfunktionen der Gasanlage bzw. zum Ausfall des Fahrzeugs kommen.

Alle Abbildungen sowie technischen Informationen, Daten und Texte waren zum Zeitpunkt der druck-legung korrekt. Die Einbauanleitung wurde von Vialle Alternative Fuel Systems BV mit größter Sorgfalt erstellt. Dennoch übernimmt das Unternehmen keine Haftung für eventuelle Fehler oder Irrtümer in dieser Einbauanleitung.

Herausgegeben von
Vialle Alternative Fuel Systems BV

INSTRUCTIONS AVANT LE MONTAGE (FRANCAIS)

- Le montage doit être seulement par les installateurs de Vialle AFS formés et assignés.
- Contrôlez si vous avez la correcte trousse avant le montage dans la voiture.
- Ces instructions de montage indiquent uniquement les informations spécifiques pour ce type de voiture, comme indiqué sur la préface.
- Pour des ultérieures informations, vous devez toujours consulter le dossier du cours de base pour les systèmes LPdi.
- Consultez le manuel d'atelier avant de démonter des pièces.
- Toutes les emplacements mentionnés dans ce manuel, sont vus de la position du chauffeur derrière le volant.
- Cylindre 1, comme d'écrit au raccordement du faisceau de câbles se trouve du côté distribution du moteur!
- Débranchez la masse de la batterie avant de commencer le montage de l'installation GPL (sauf si stipulé autrement dans les instructions d'atelier). Attention: les mémoires de la radio et/ou du téléphone peuvent éventuellement être effacées, le verrouillage central peut se fermer et l'alarme peut se déclencher. Si nécessaire, la batterie peut être rebranchée temporairement.
- Ebarbez les trous percés, enlevez la limaille éventuelle de la voiture et traitez les bords avec un produit antirouille.
- Posez le faisceau de câbles de telle façon qu'il ne peut pas se déchirer et/ou s'endommager par une source de chaleur et/ou quand il se trouve trop près des parties d'allumage. Fermez les fissures ouvertes après le montage du faisceau de câble avec du caoutchouc au silicone pour éviter le bruit et les fuites d'eau.
- Coupez les fils sans connecteur selon la correcte longueur, le fil rouge doit être coupé le plus court possible. Ne pas enrouler la longueur superflue (éventuelle) des fils avec connecteur à cause d'interférences, mais écartez avec un « détour ».
- Les connections électriques doivent être faites avec les connecteurs livrés ou au moyen du soudage et du finissage avec une gaine rétractable.
- Montez les fusibles livrés selon le schéma électrique.
- L'installation GPL doit être montée et les liaisons de gaz entre les différentes pièces du GPL doivent être contrôlés suivant les prescriptions de l'Etat sur les installations GPL.

Le non-respect des instructions de ce manuel, peut causer un dysfonctionnement de l'installation de gaz, ou peut occasionner une situation dangereuse.

Les images, les informations techniques, les données et les textes étaient corrects lors de la mise en impression. En dépit de tous les soins apportés à la composition de cette édition, aucun responsabilité ne pourra être acceptée sur base d'une erreur ou d'un malentendu que cette édition pourrait contenir.

Édité par
Vialle Alternative Fuel Systems BV

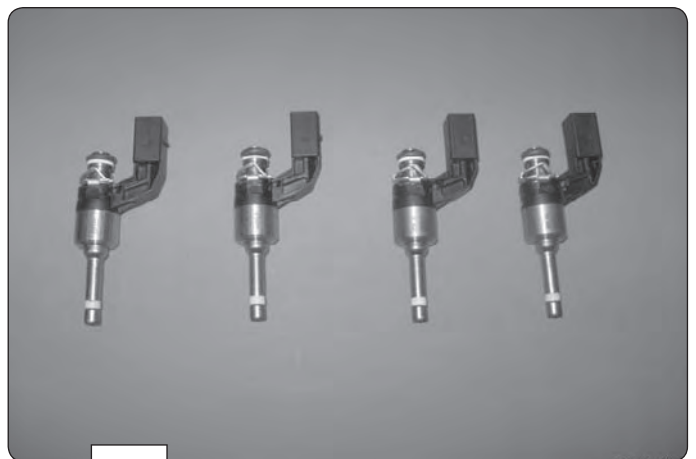
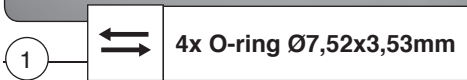
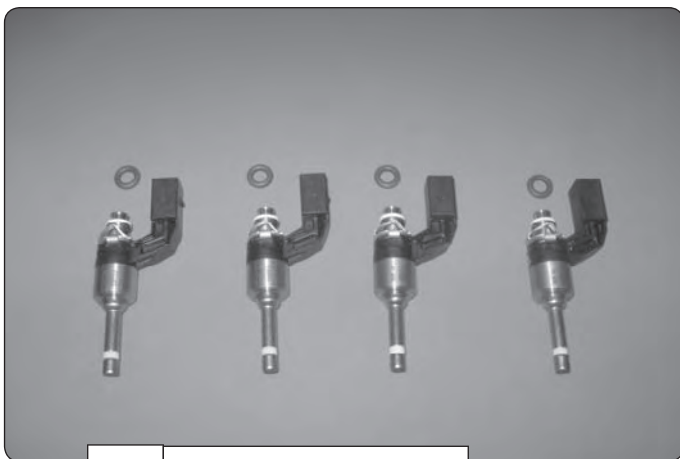
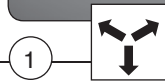
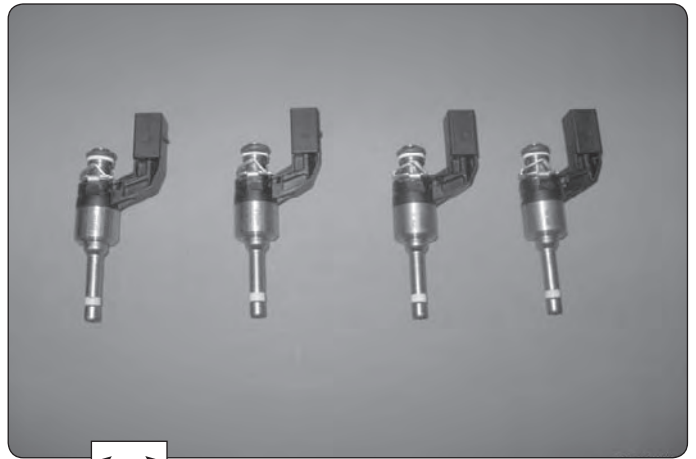
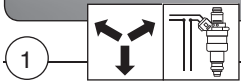
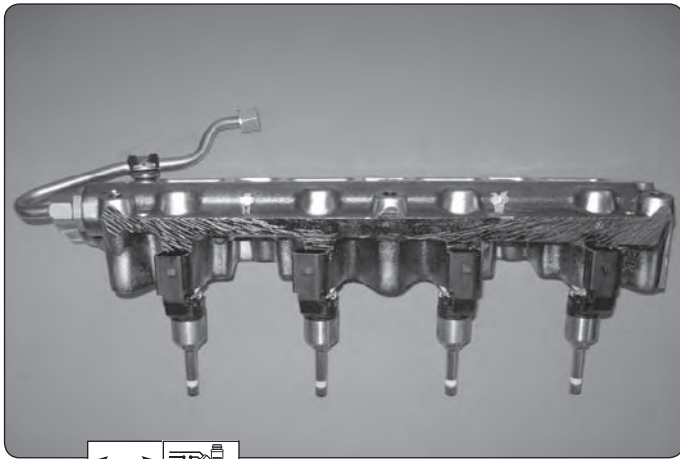
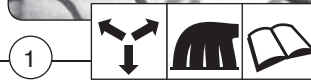
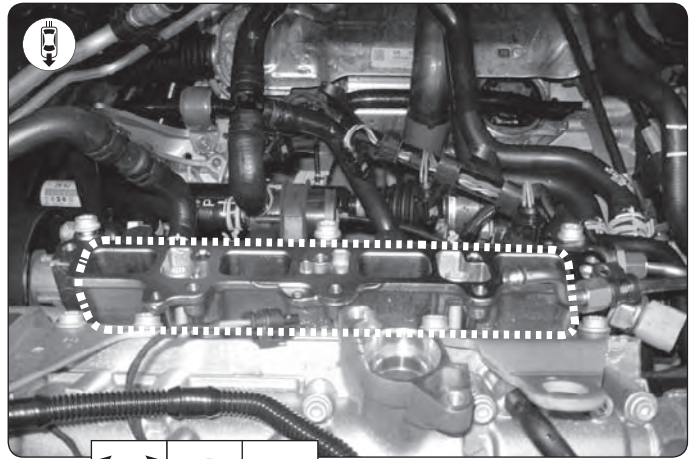
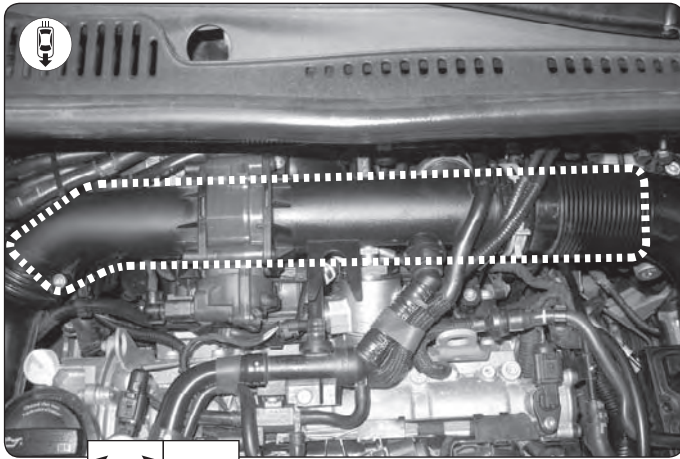

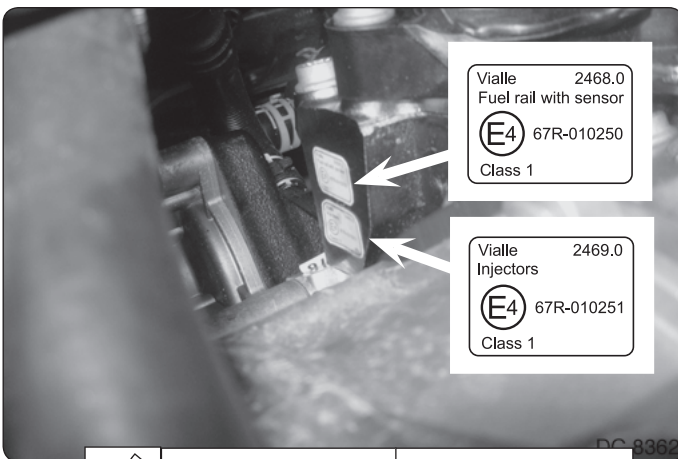
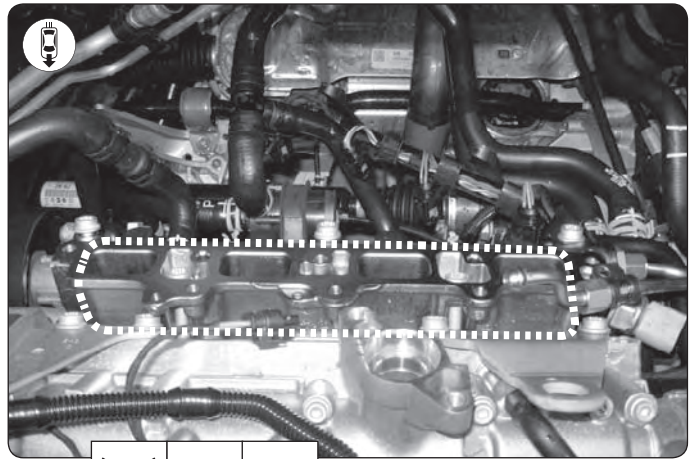
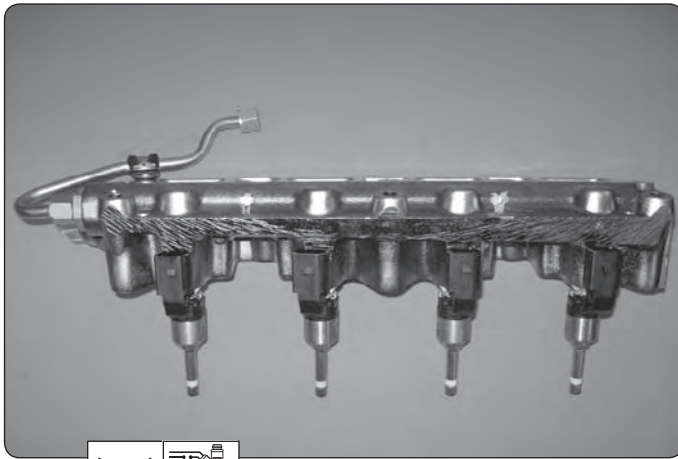
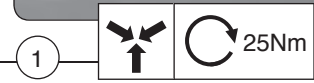
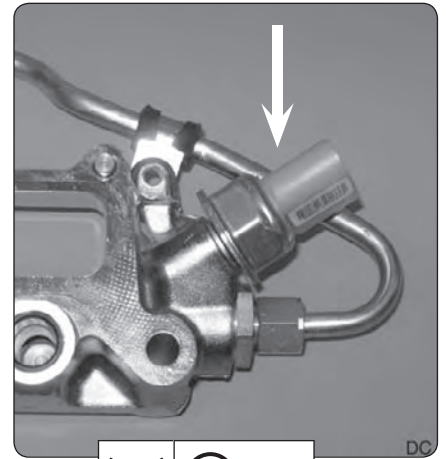
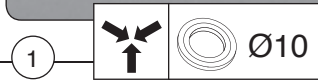
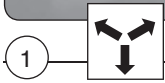
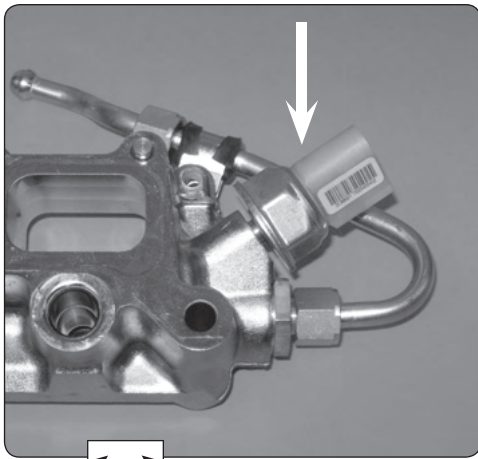

Vialle 2468.0
Fuel rail with sensor
E4 67R-010250
Class 1

Vialle 2469.0
Injectors
E4 67R-010251
Class 1

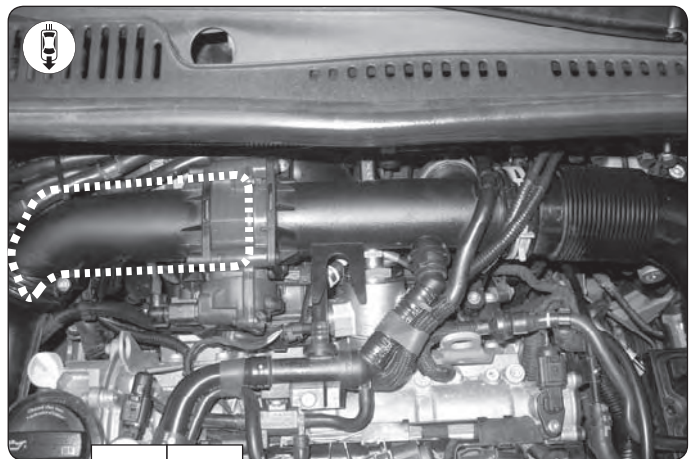
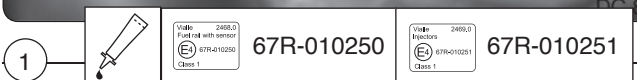

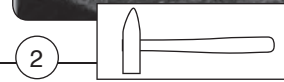
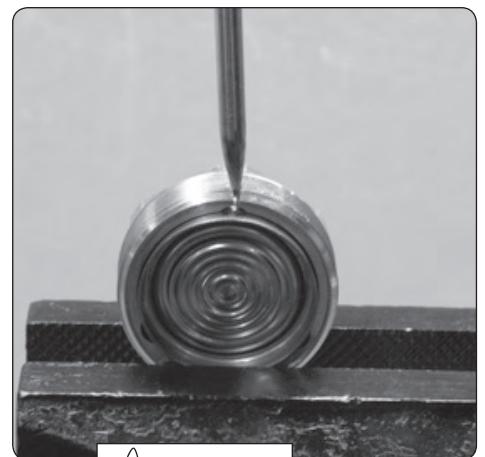
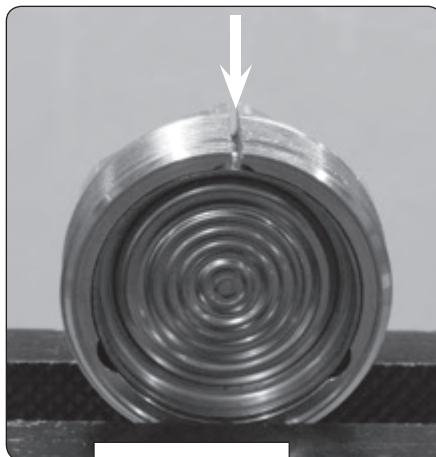
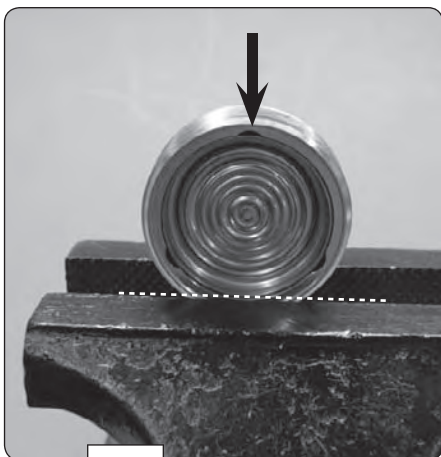
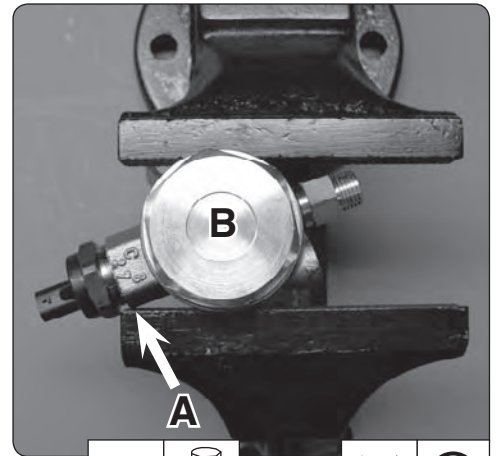
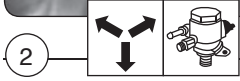
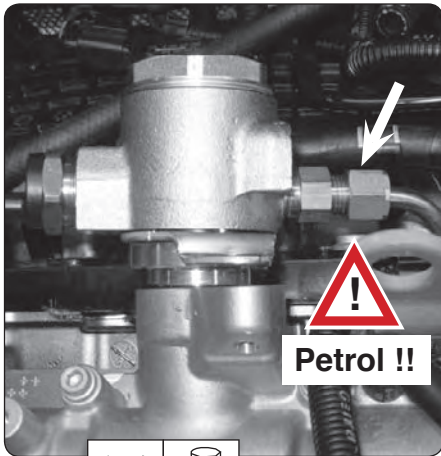
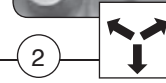
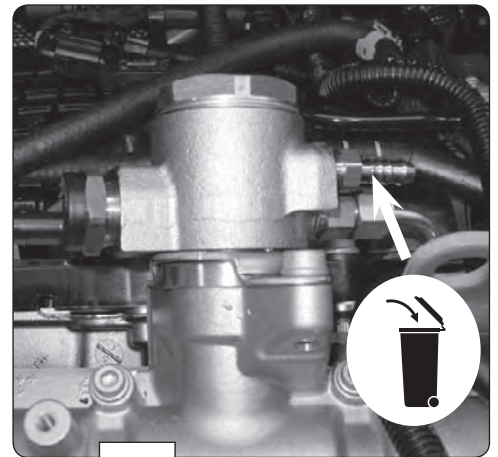
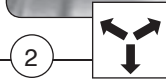
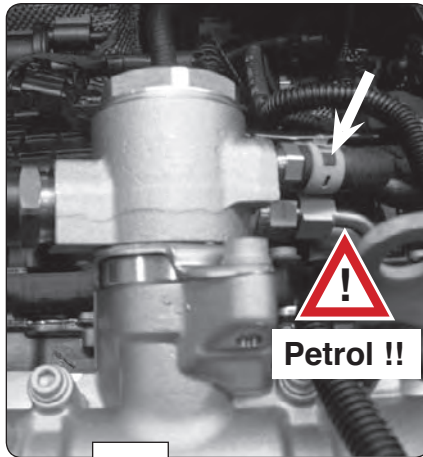
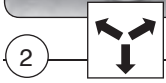
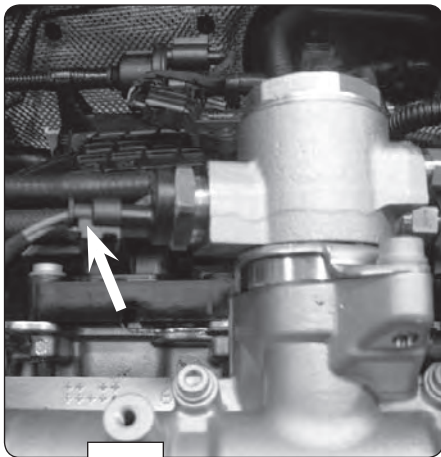

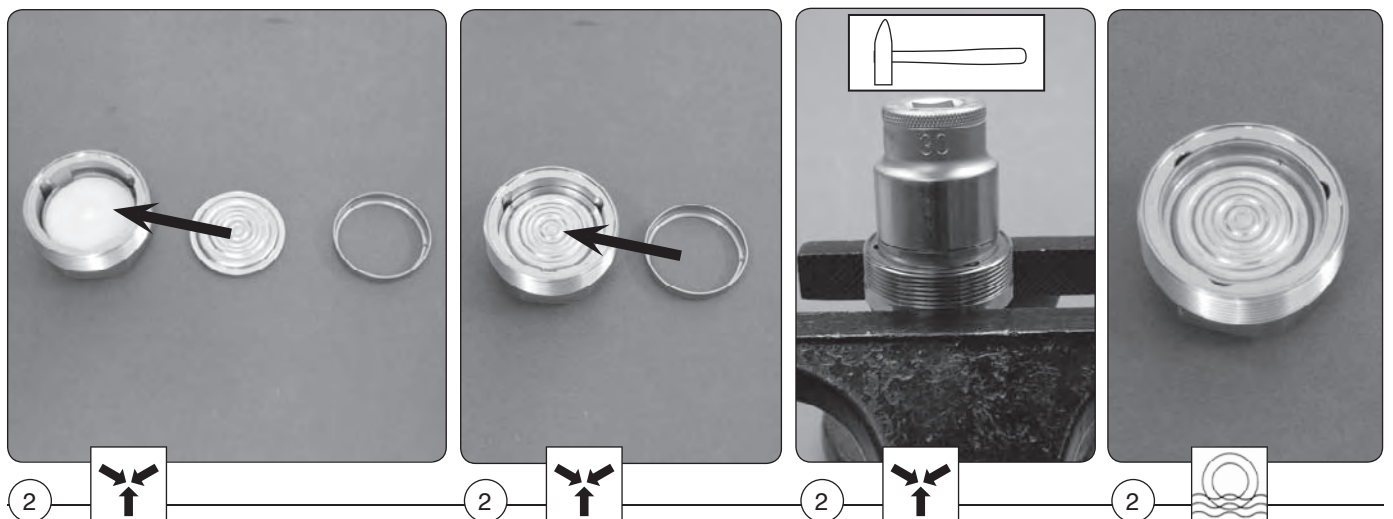
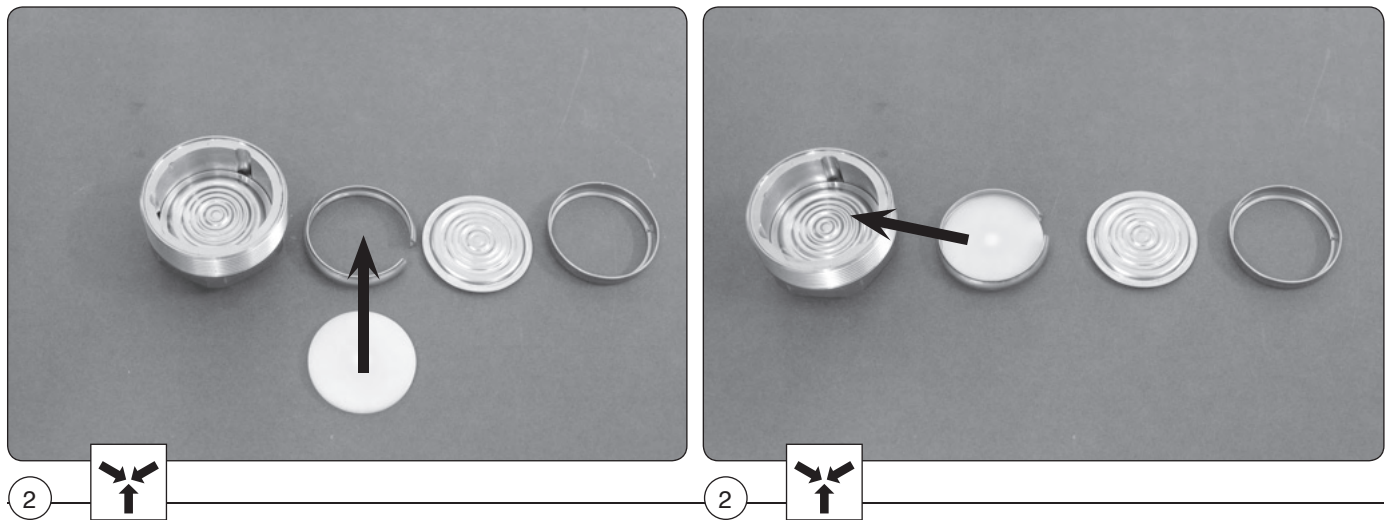
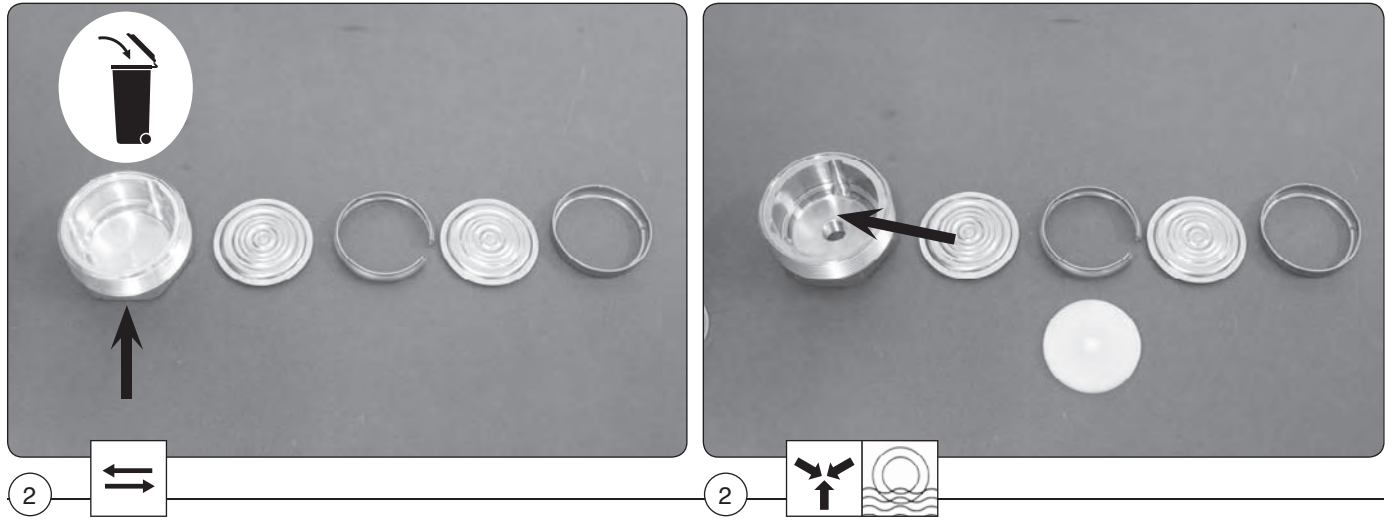

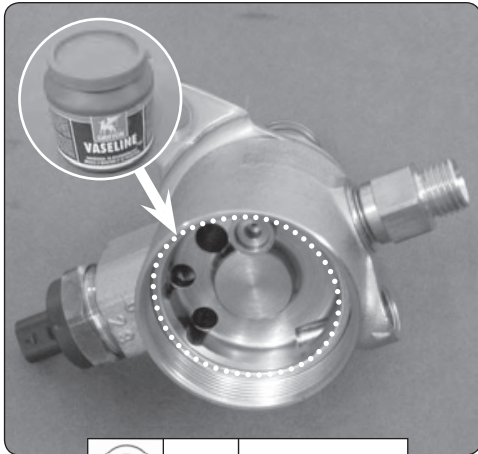

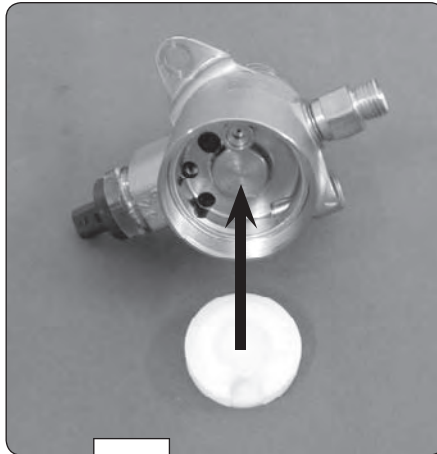

2   **ACID FREE VASELINE**



2 



2 

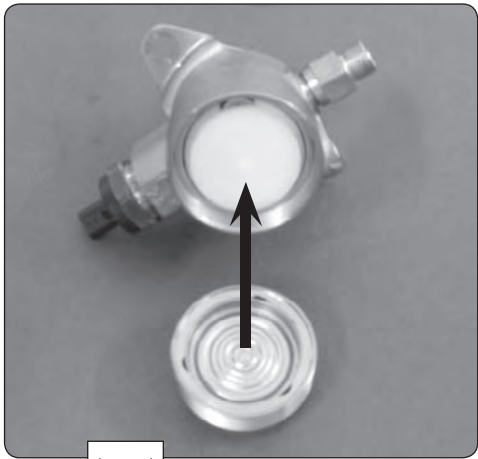

2 

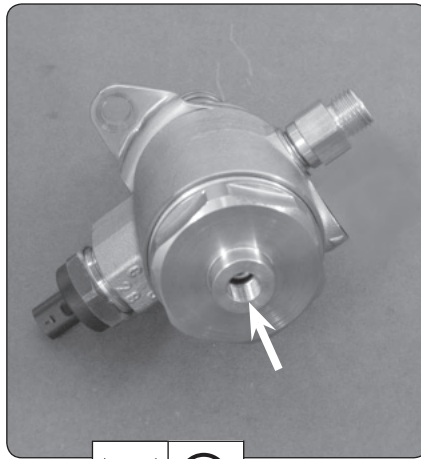

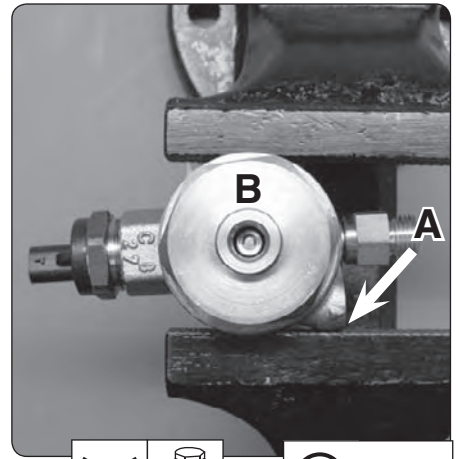

2  

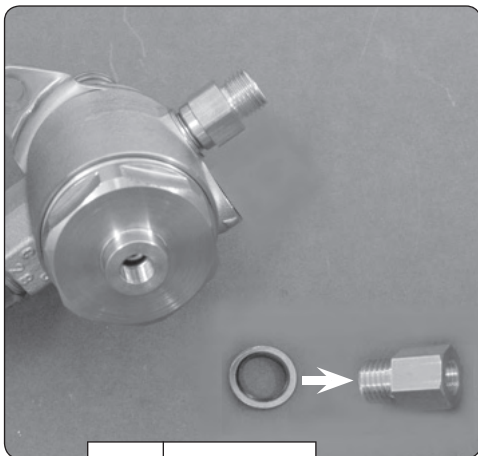

2A   2B  220Nm





2   Ø12

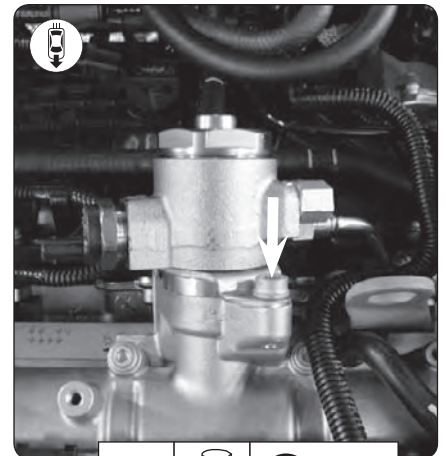

2   10Nm



2    15Nm

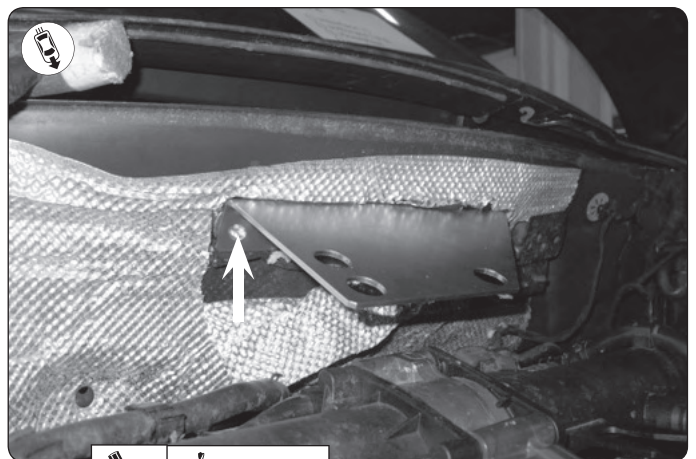
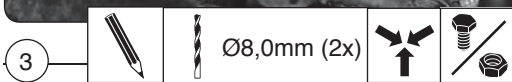
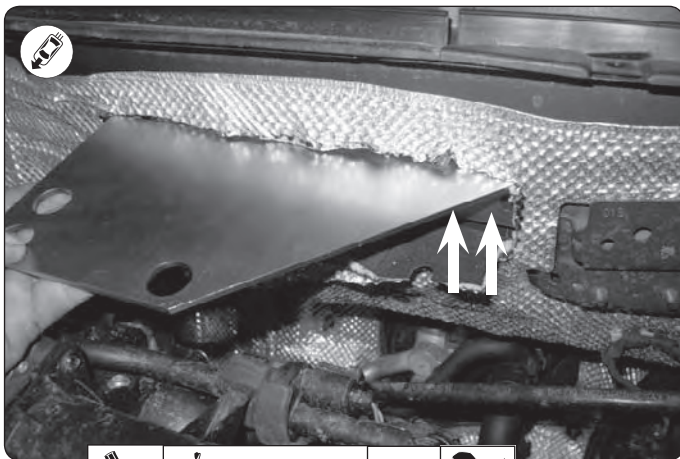
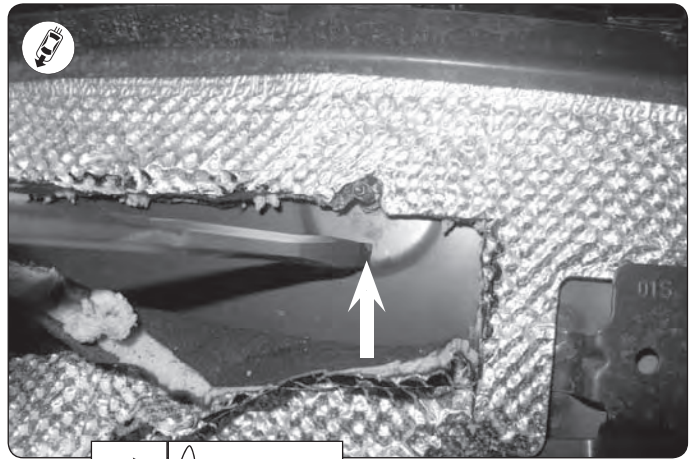
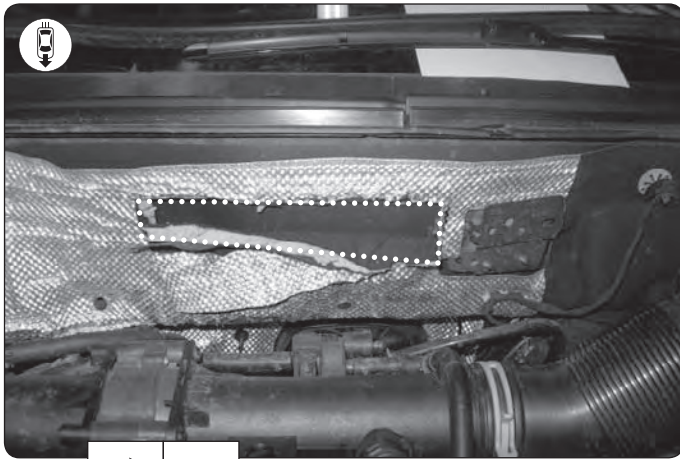
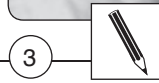
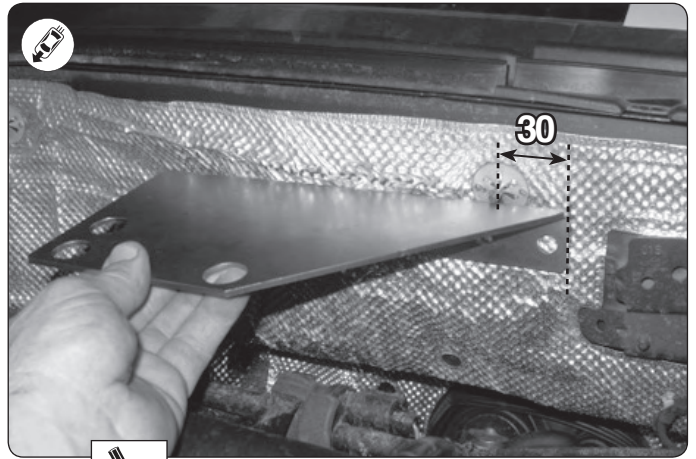
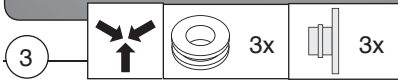
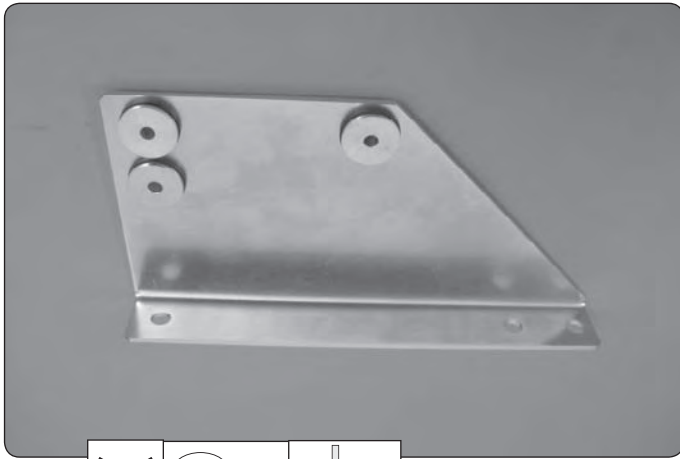

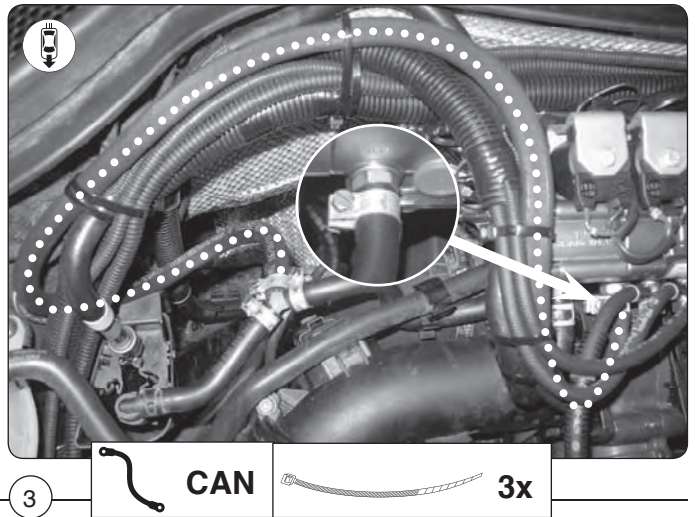
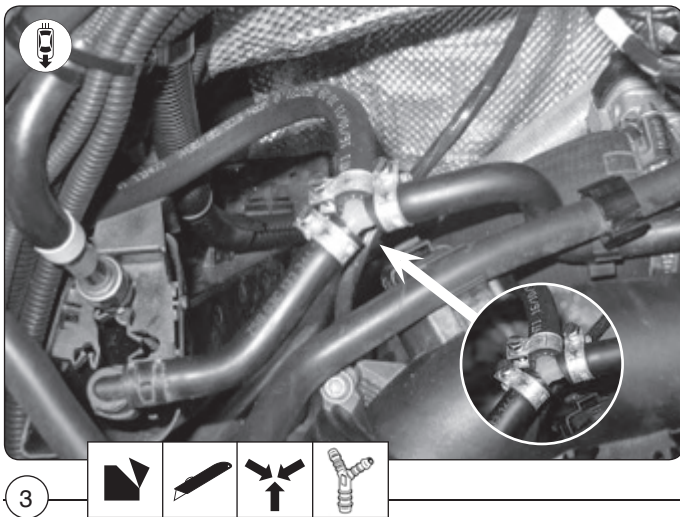
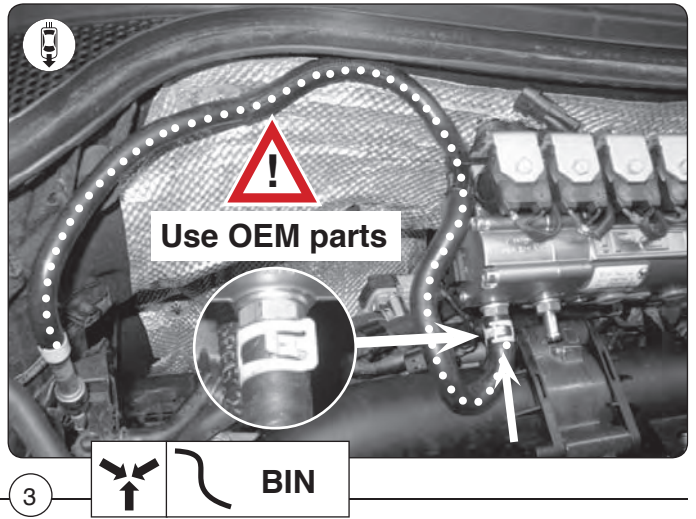
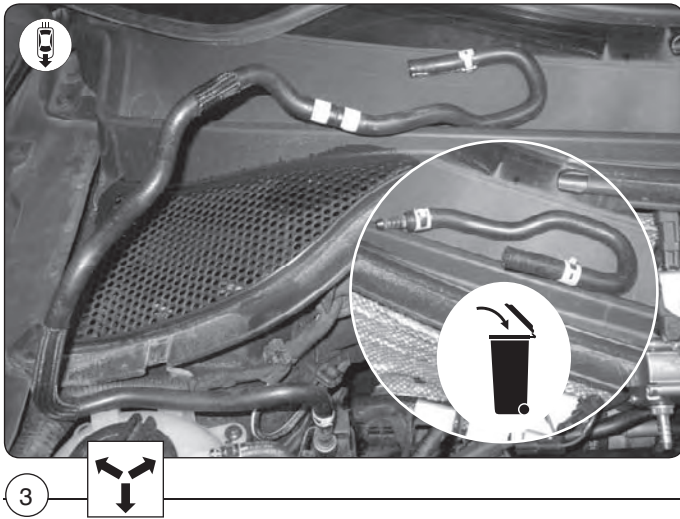
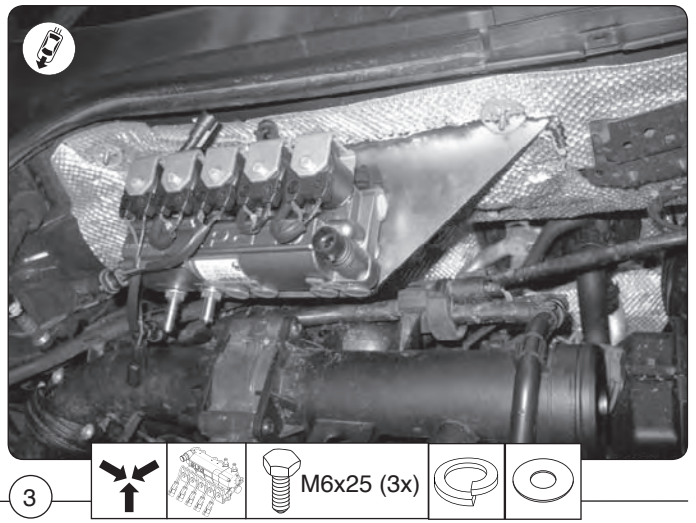
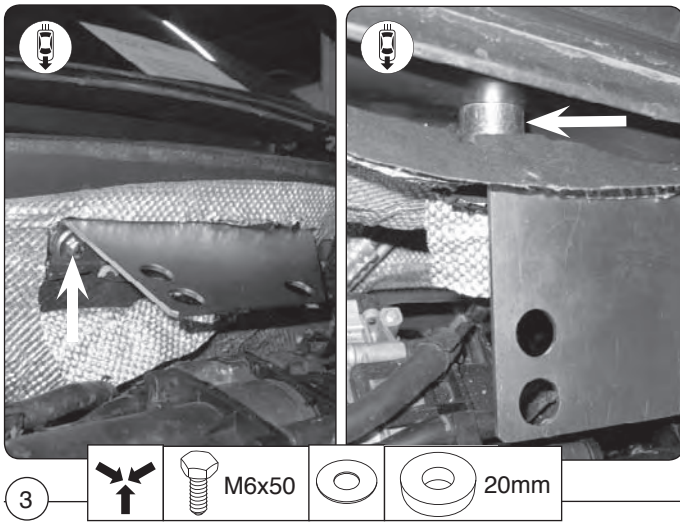



3 



3   10Nm

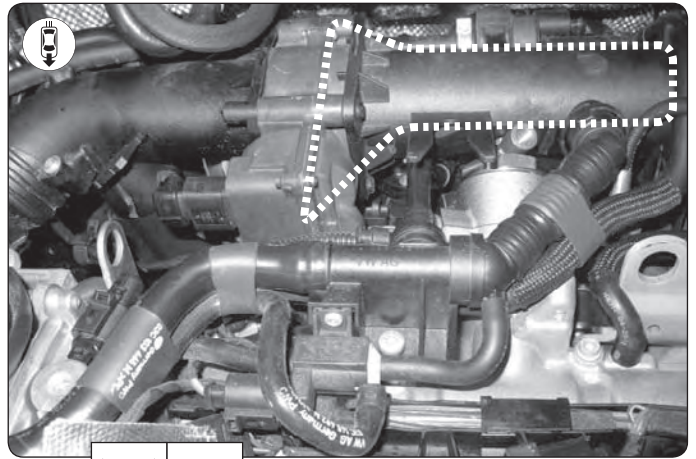

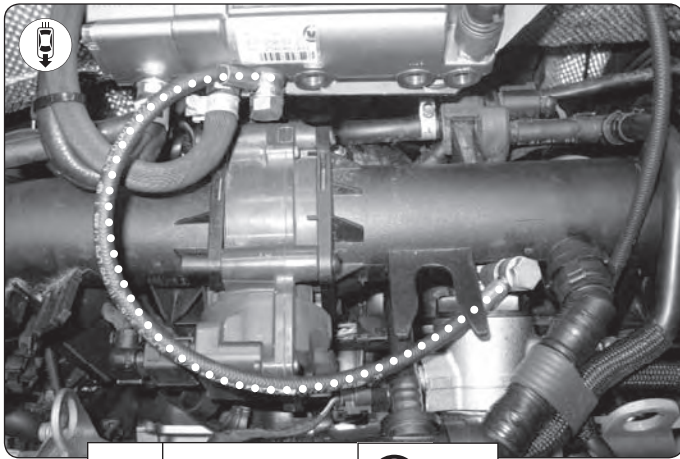

3  

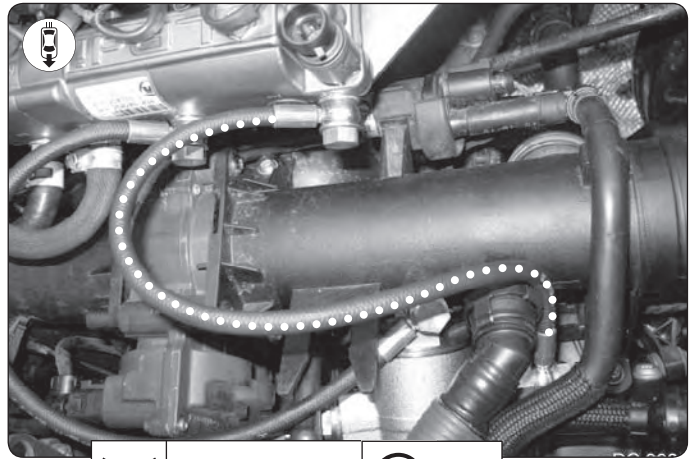

3   HP2  10Nm



3   HP1  10Nm

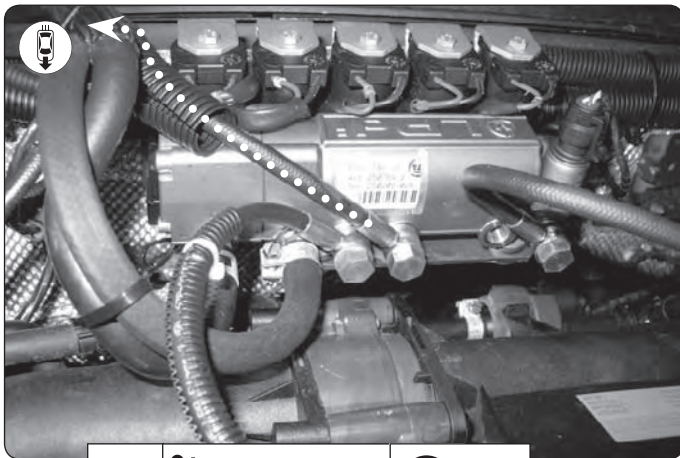

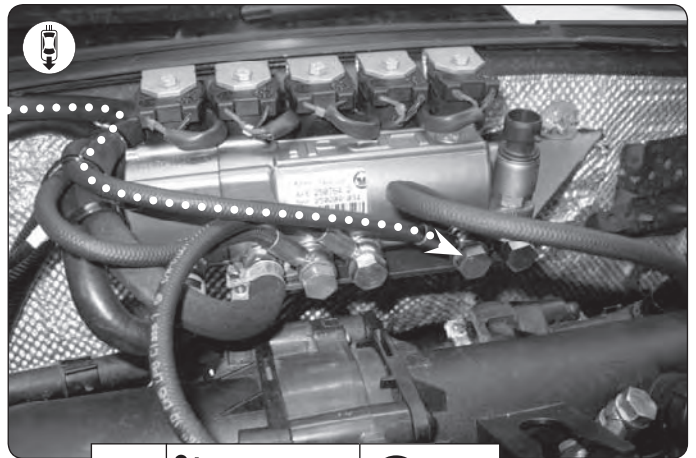

3   GOUT  10Nm



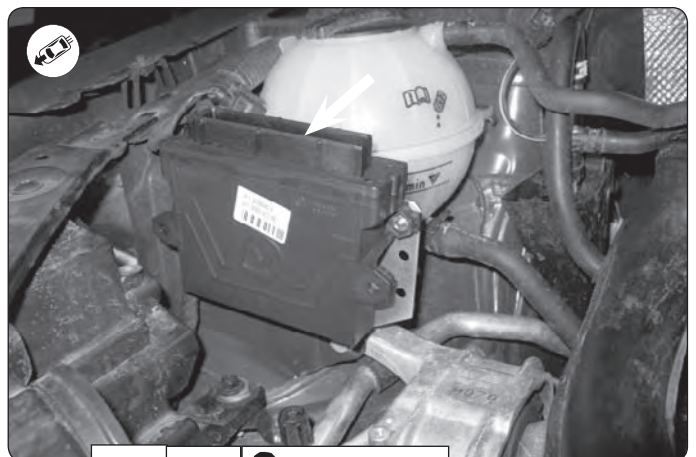
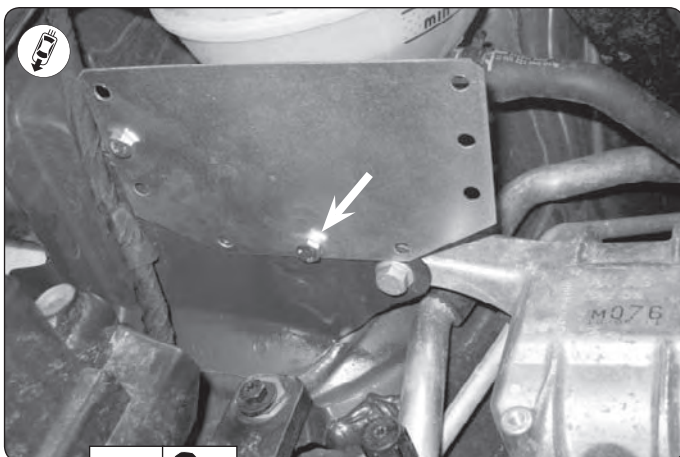
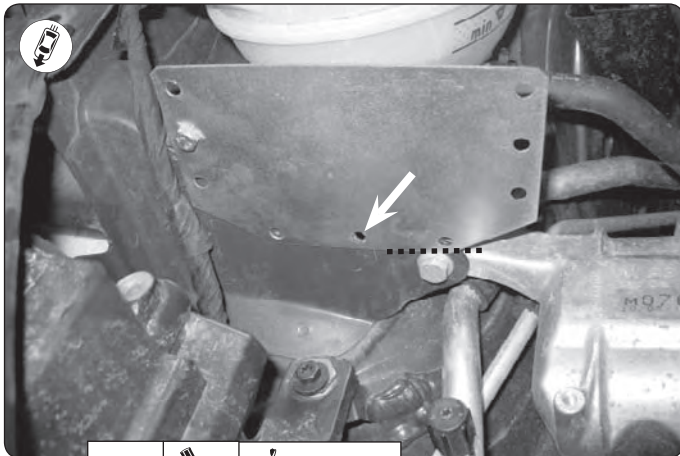
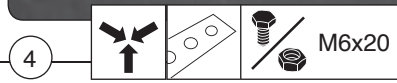
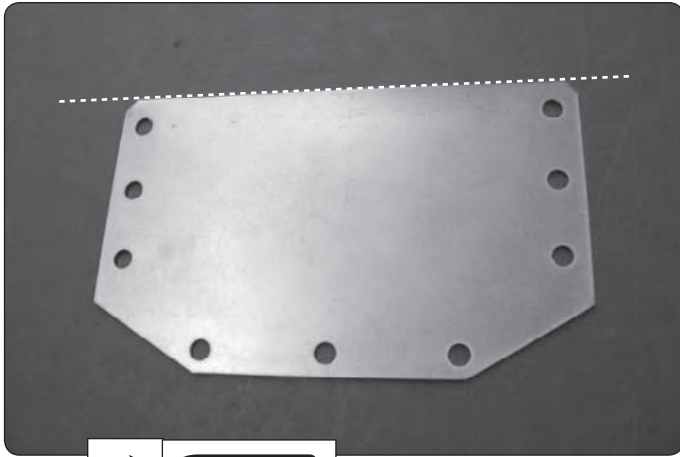

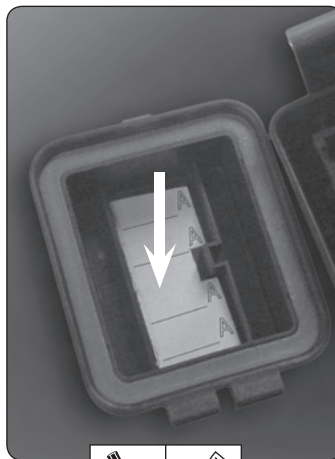
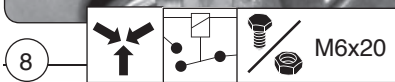
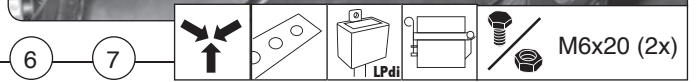
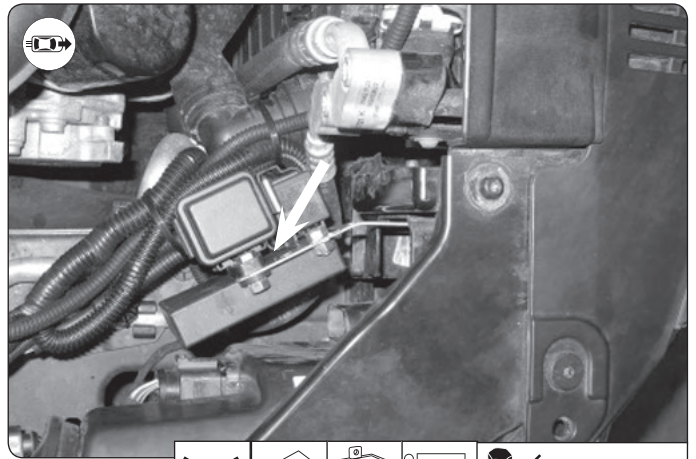
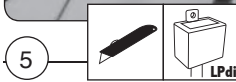
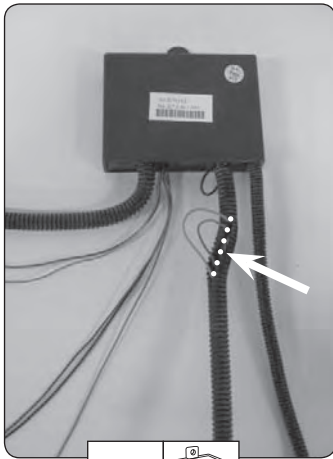
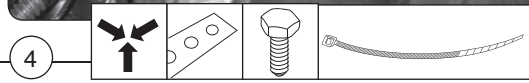
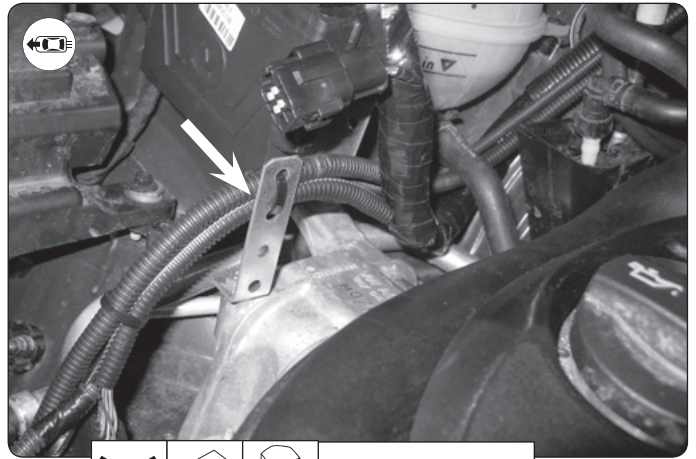
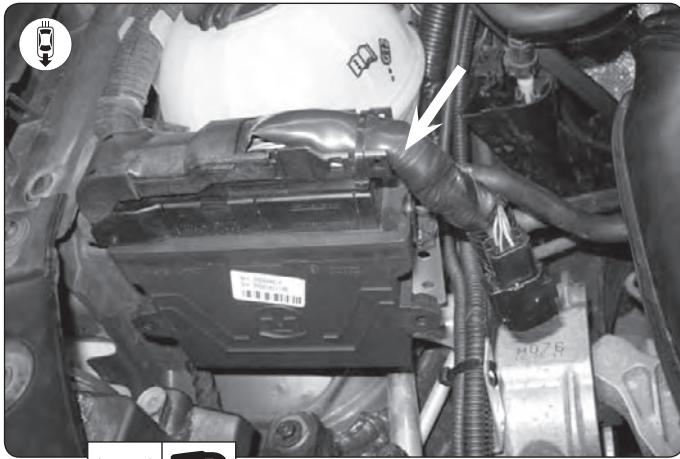
3   GIN  10Nm



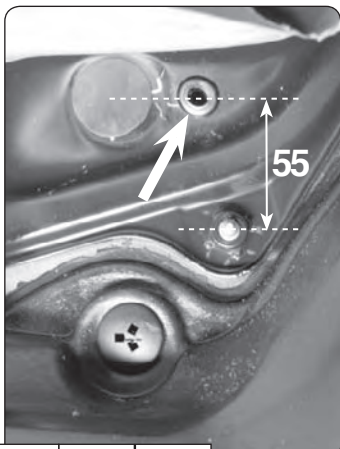

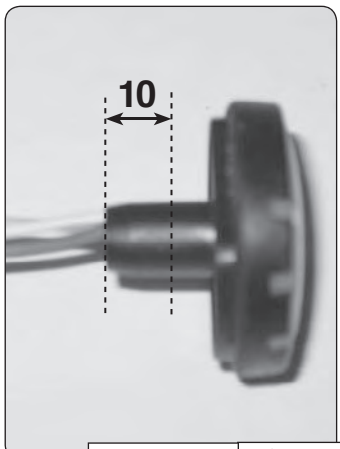







9



10

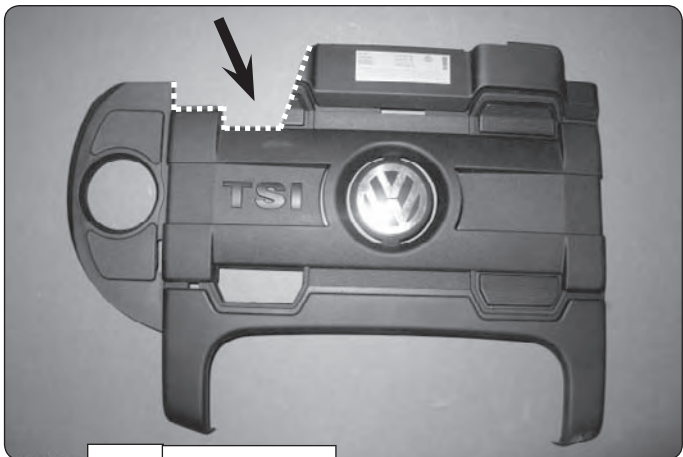



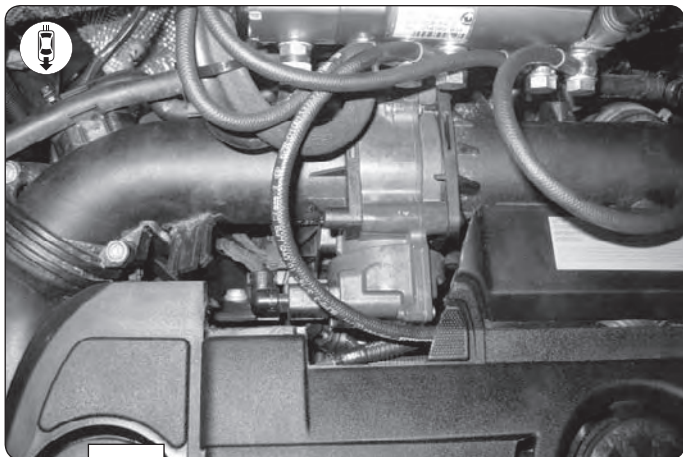

3

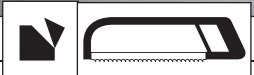

3



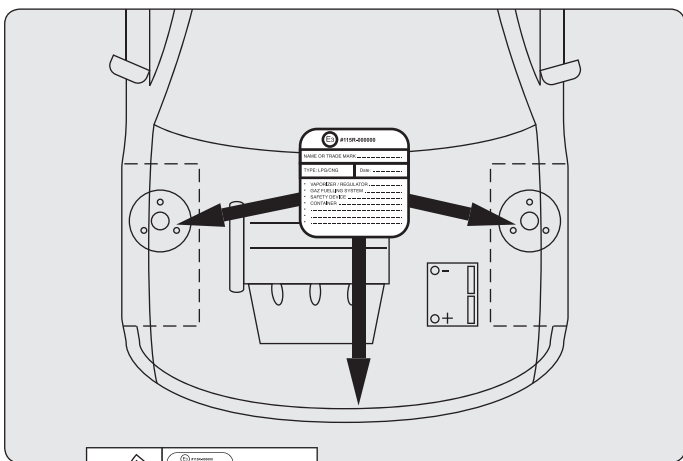

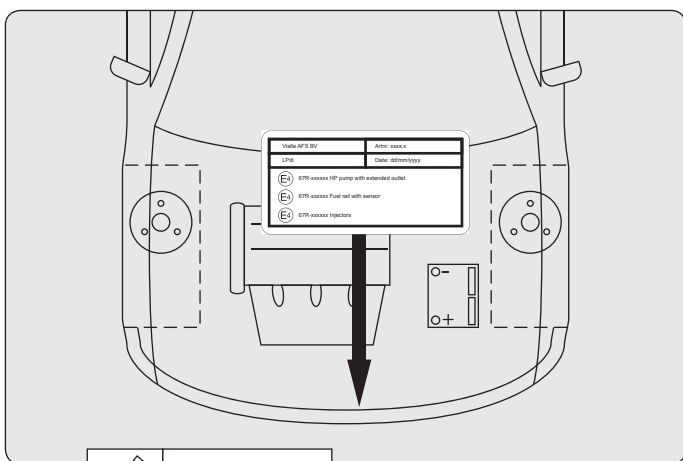

R115



67R01



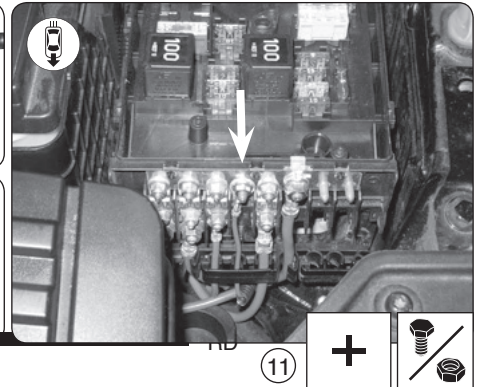
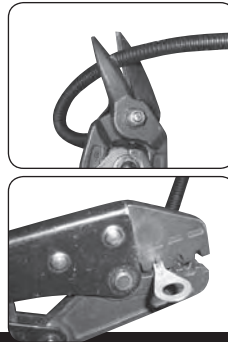
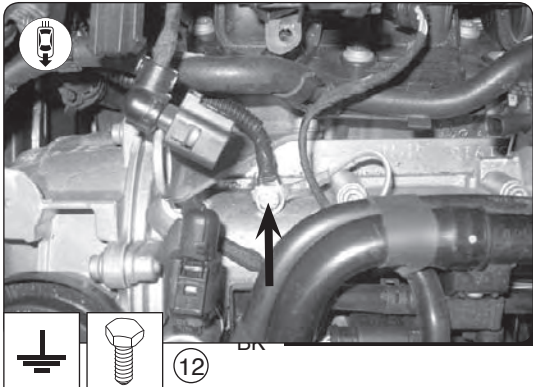

WH/BK

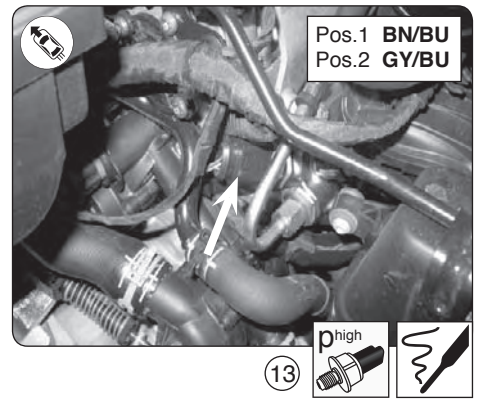
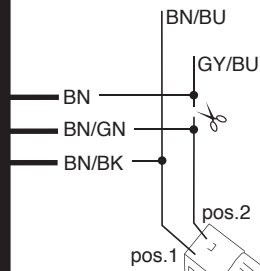

Petrol pressure high



15

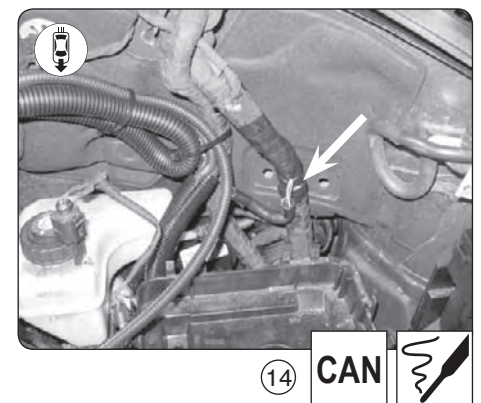
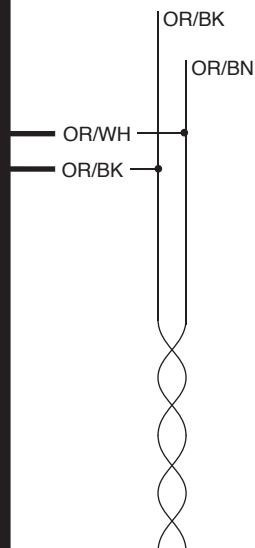

ECU PETROL

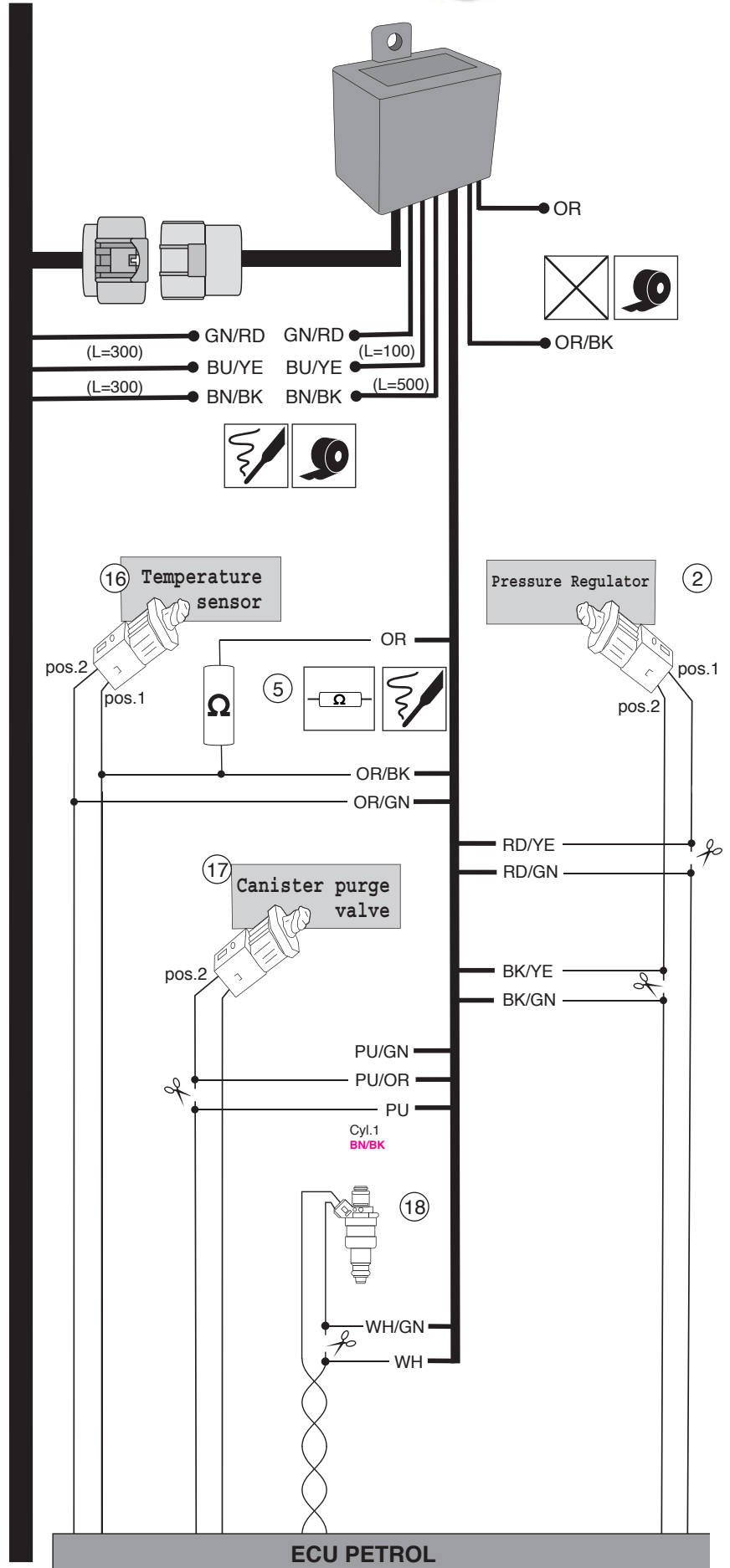
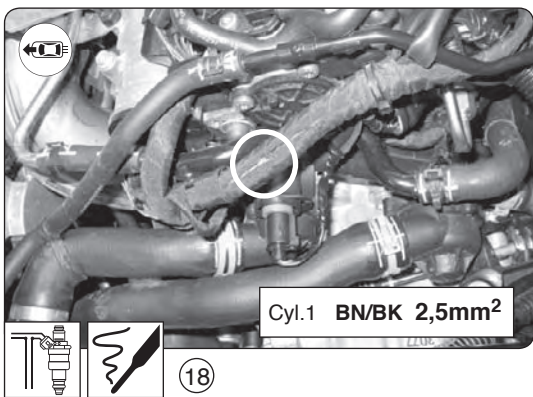
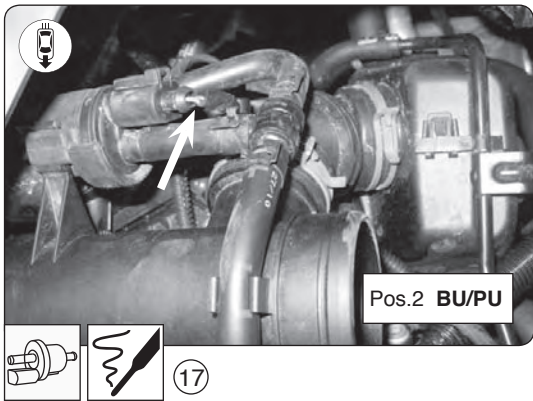
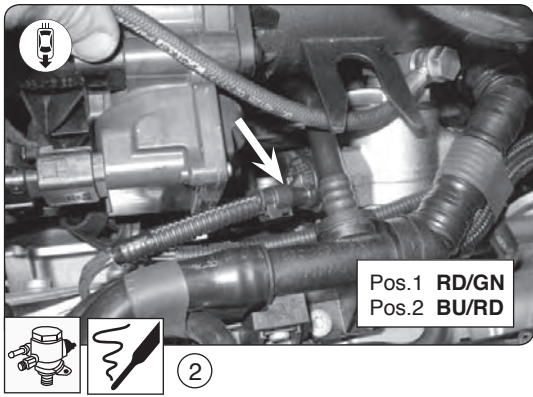
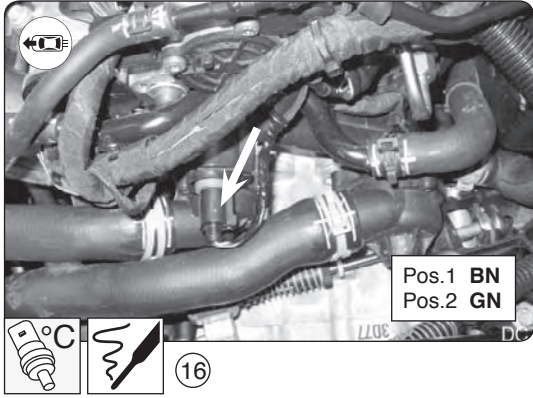

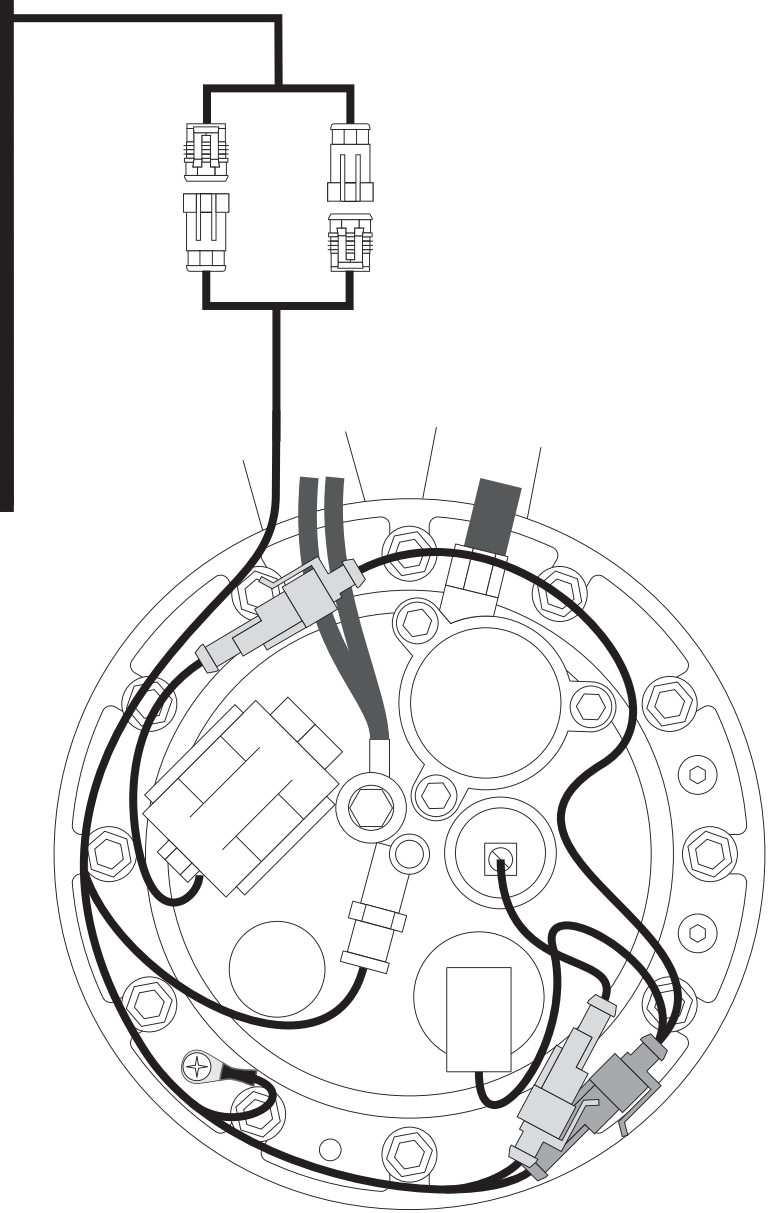
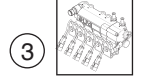
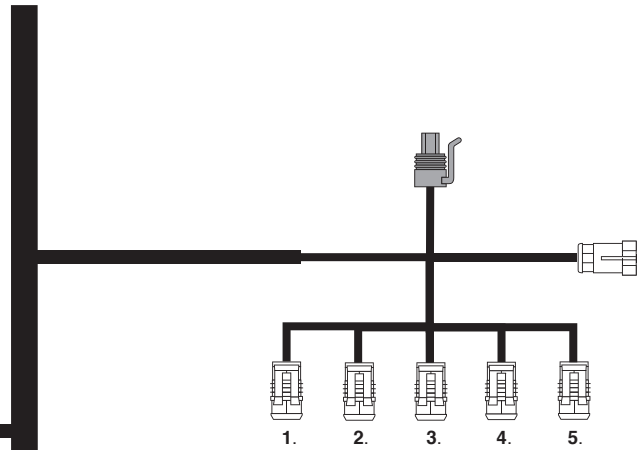
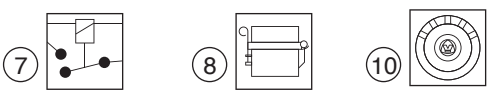
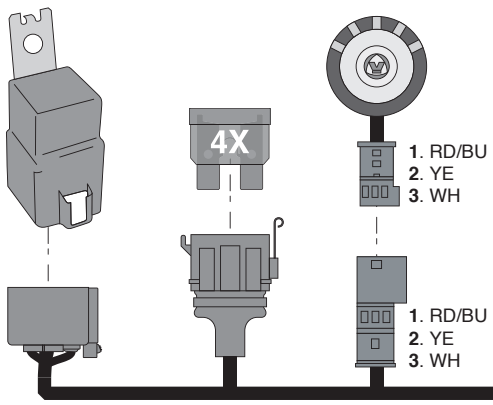
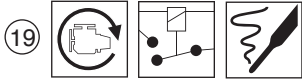
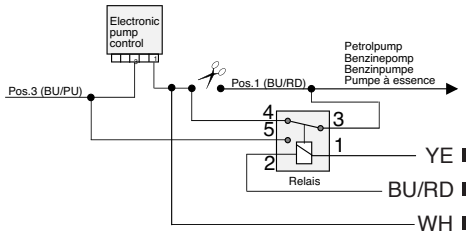
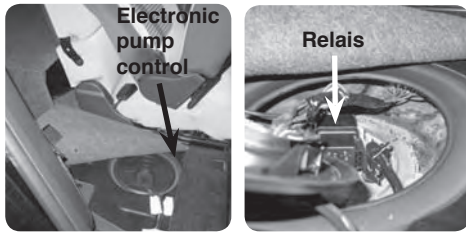



T1

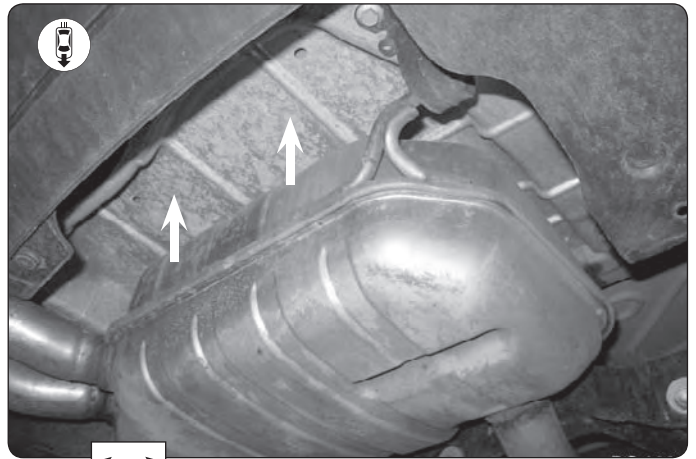

T1

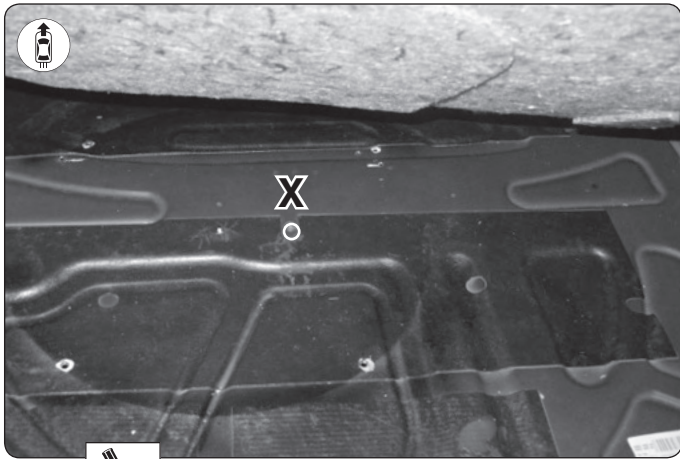

T1

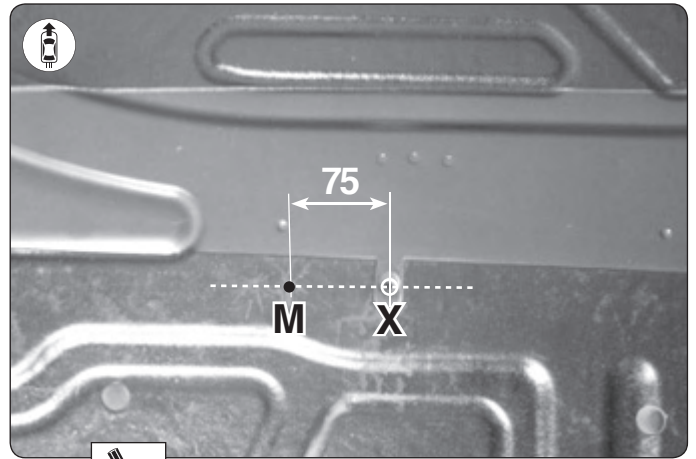

T1

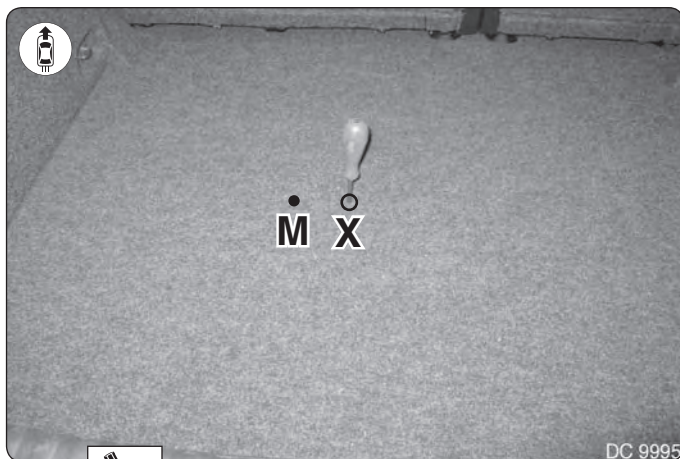

T1



DC 9995

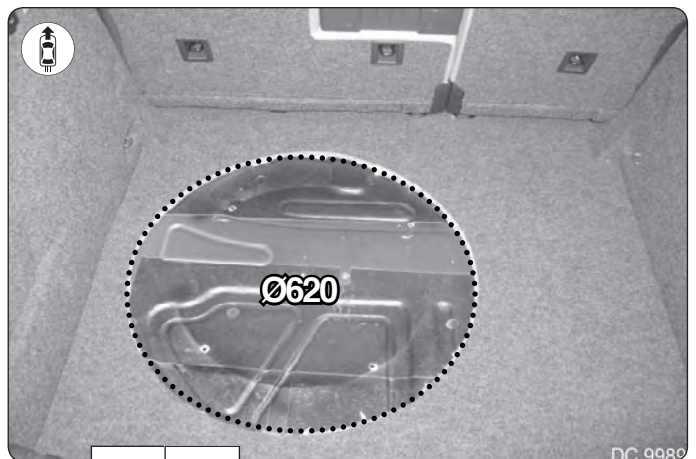

T1



DC 9989

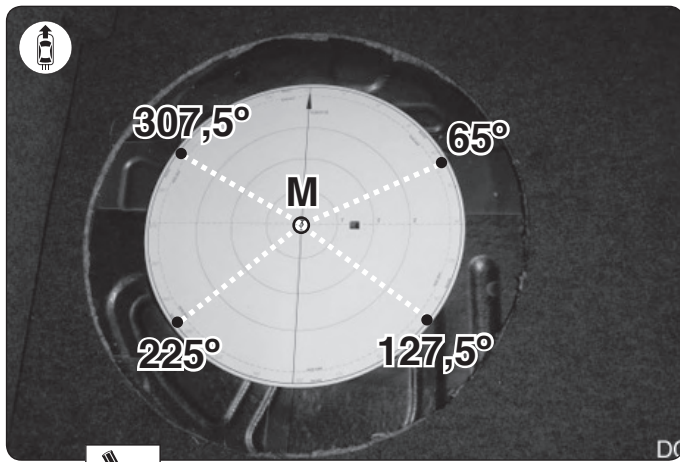

T1

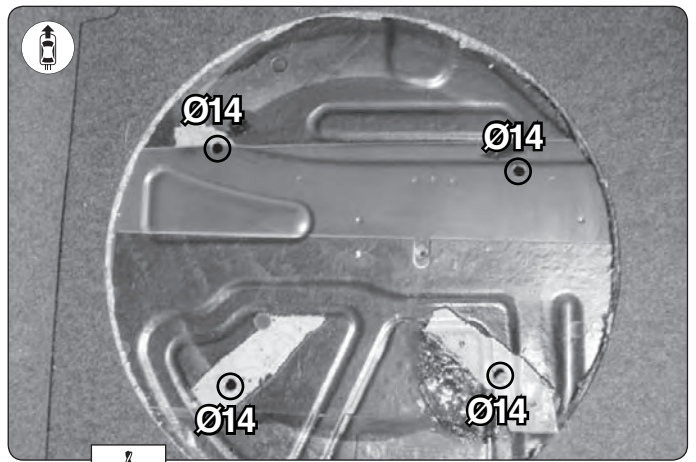

T1

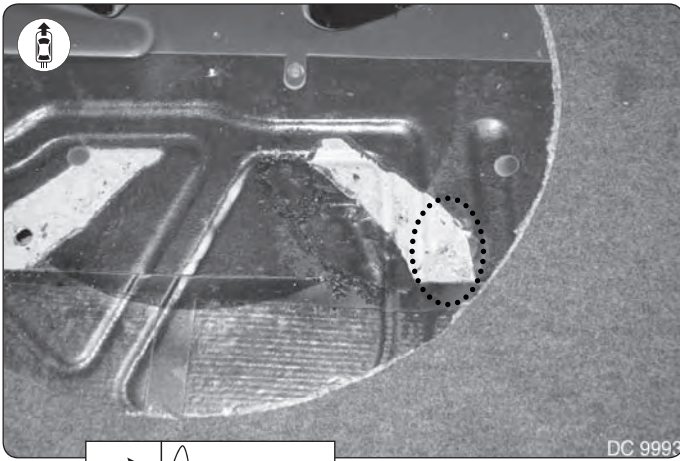

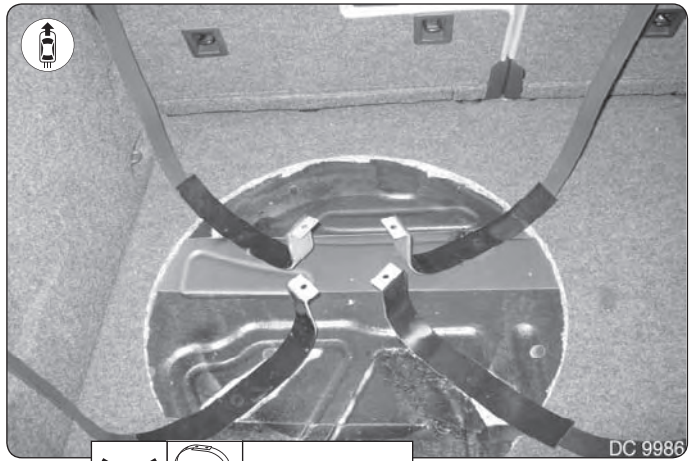
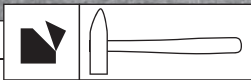

T1



T1

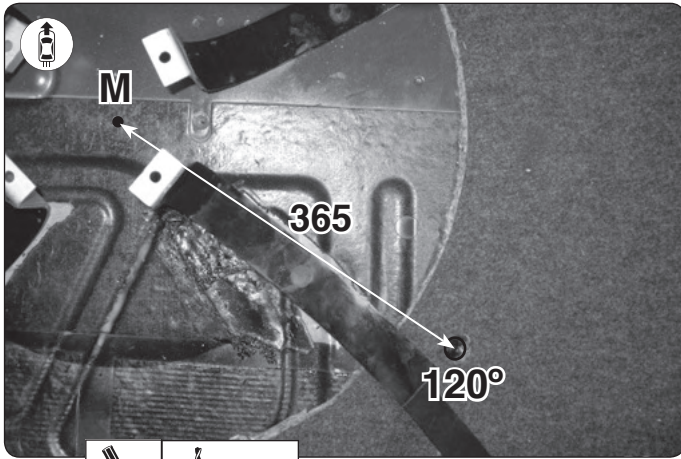



T1   Ø30

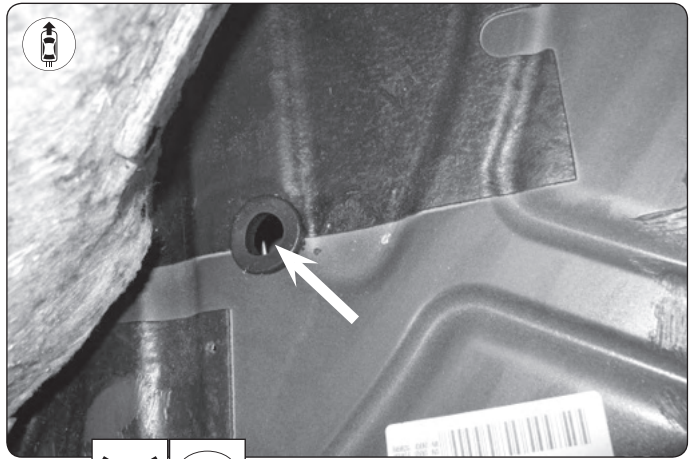

T1  

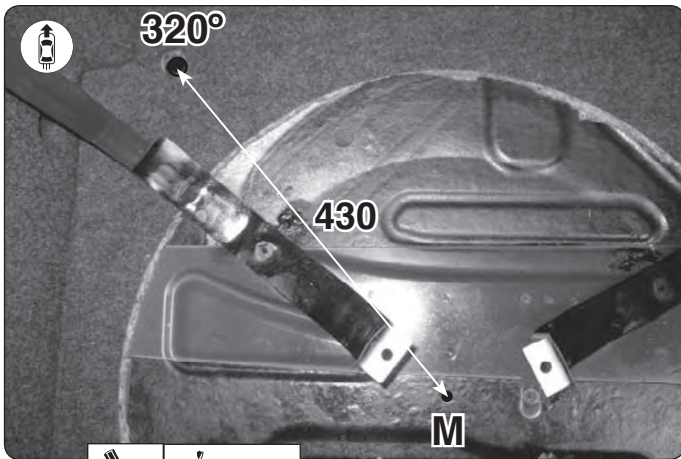

T1   Ø32

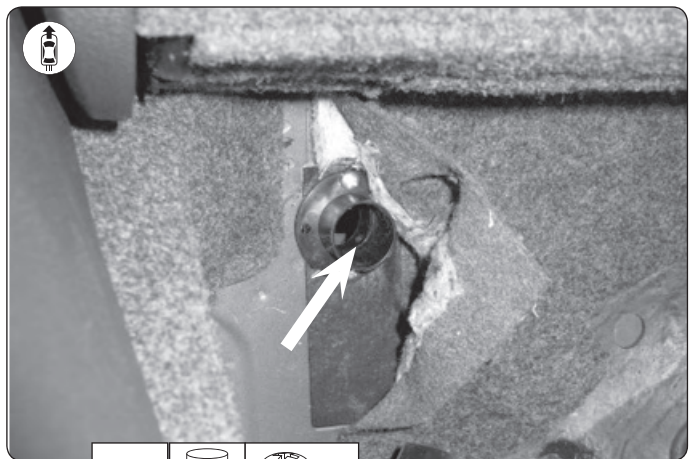

T1    4x

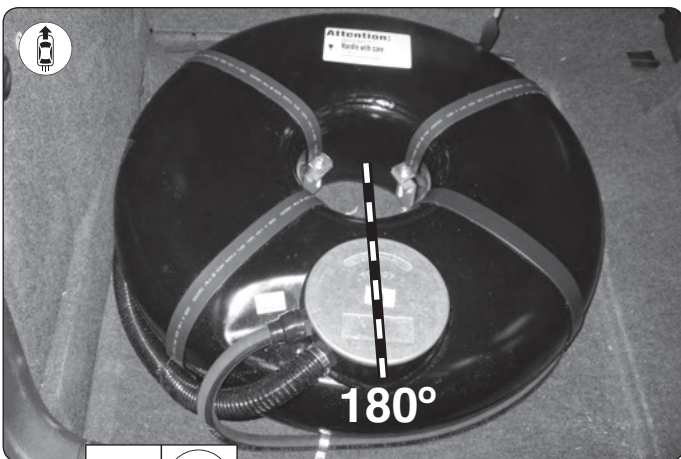

T1  

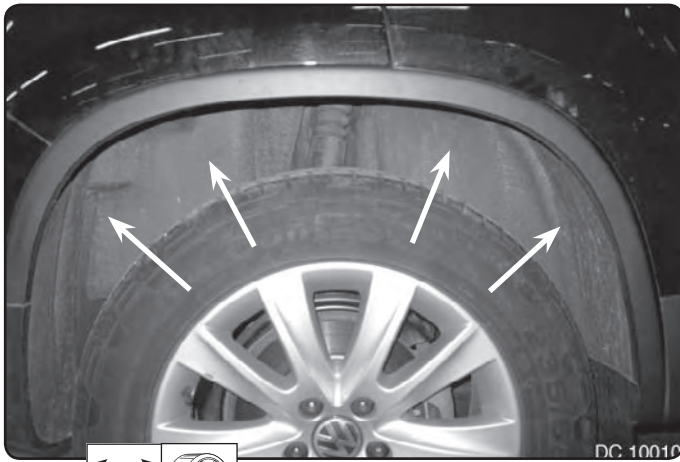

T1  

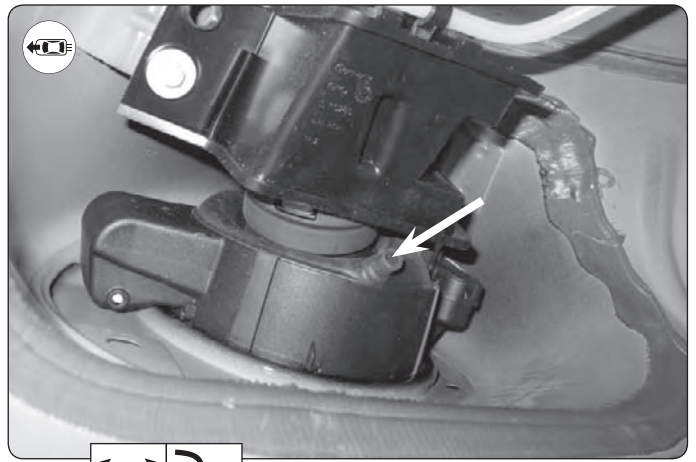

T1  

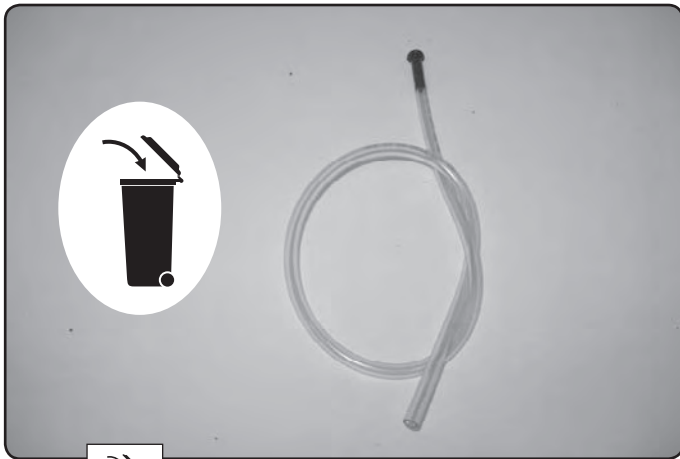

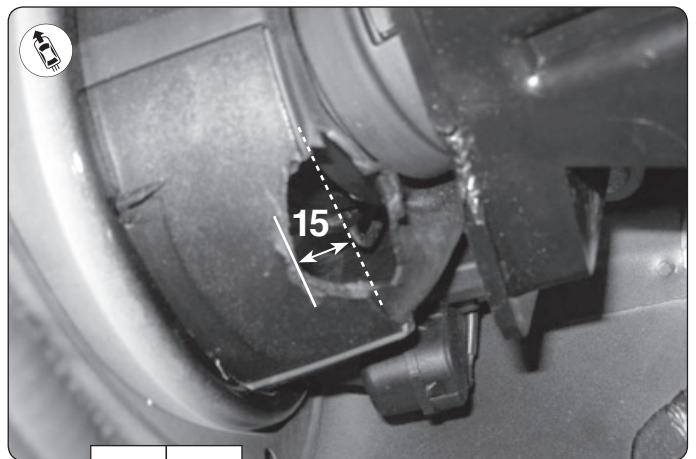

T1 

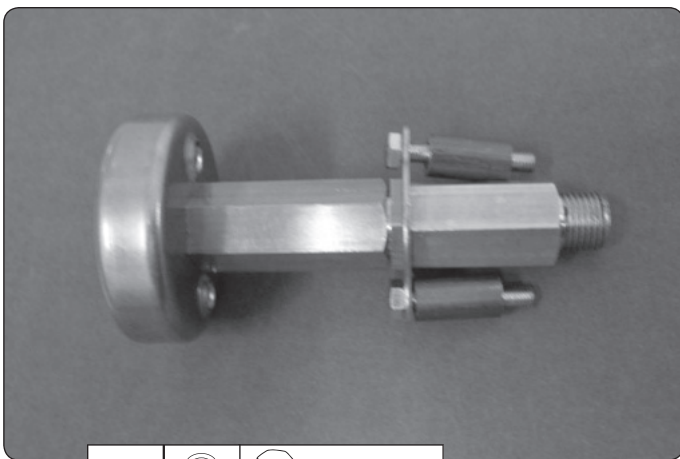

T1  



T1    2x M6x30

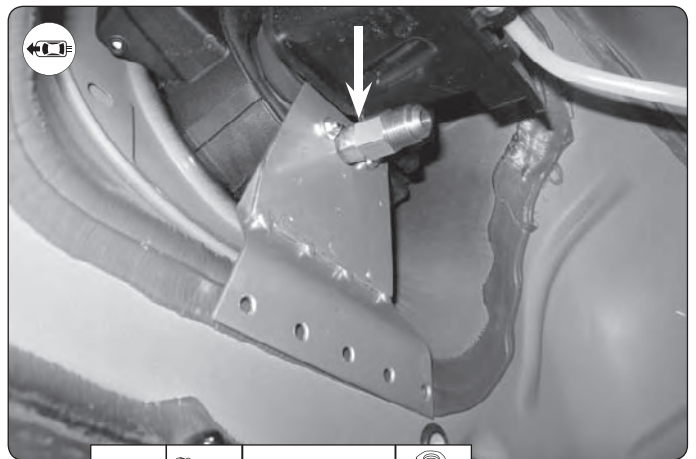

T1    Ø12 

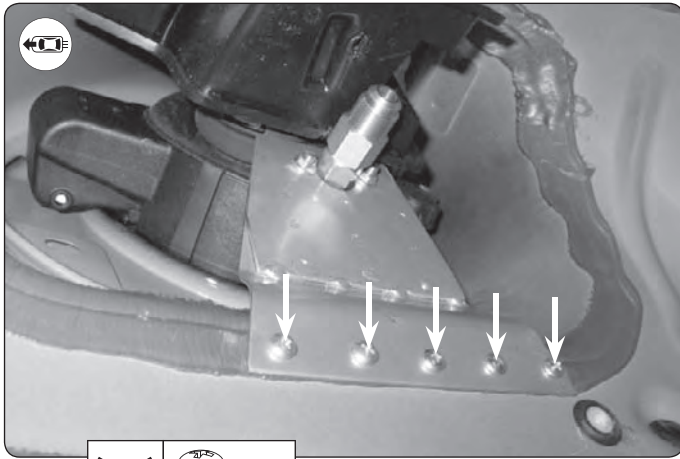

T1   5x

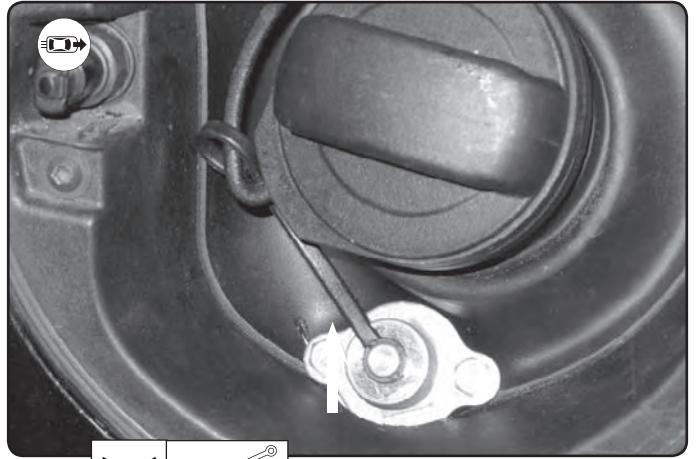

T1  

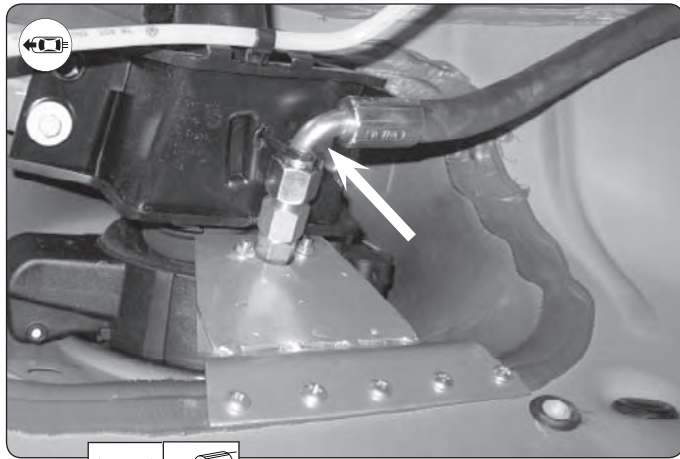

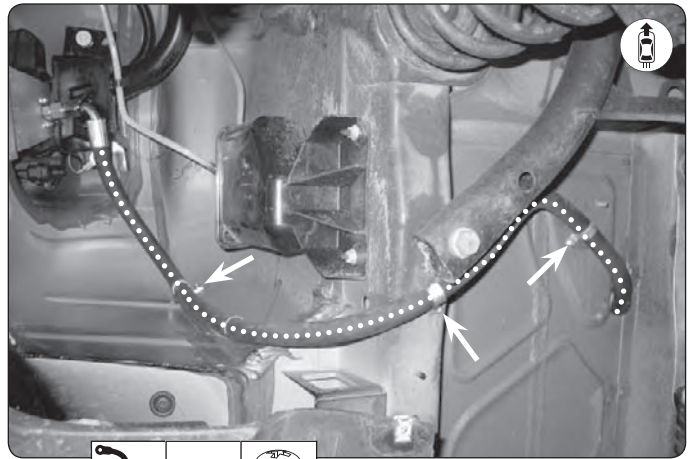

T1  



T1   



T1   

DC 9988

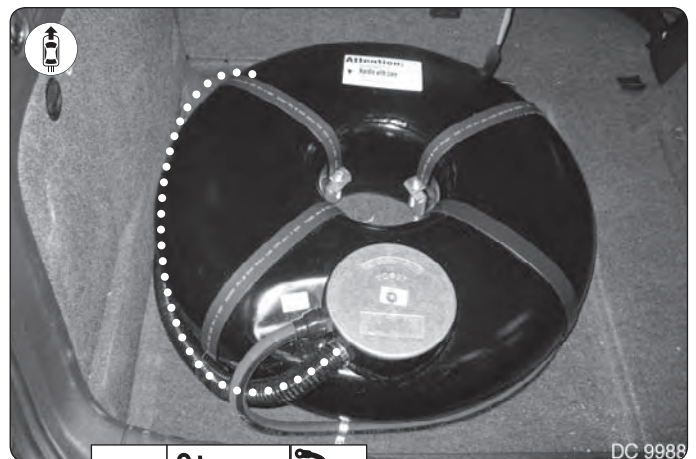

T1   

DC 9988

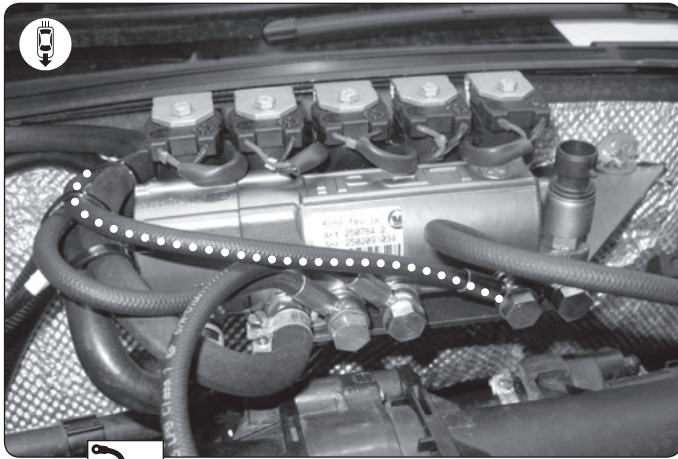

T1

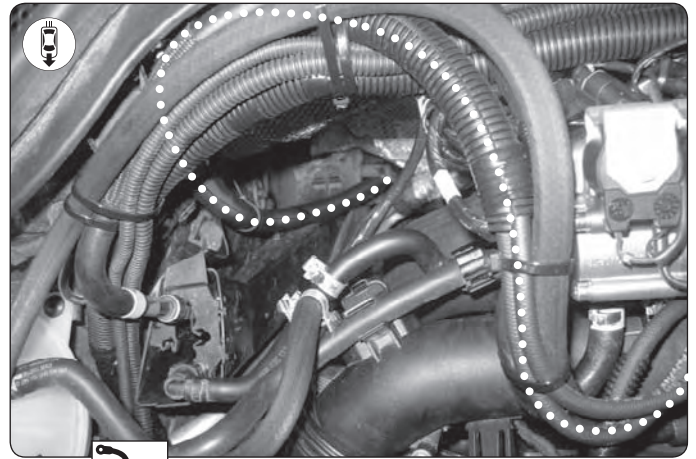

T1

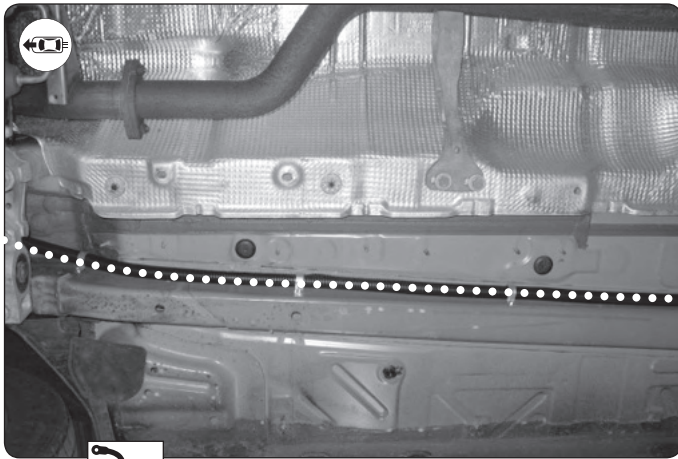

T1

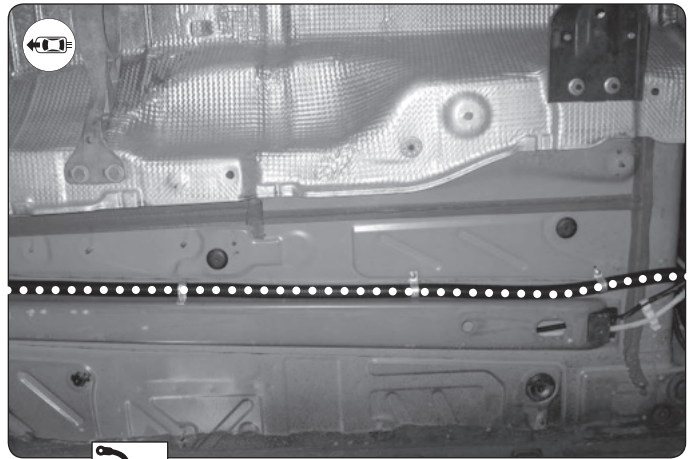

T1

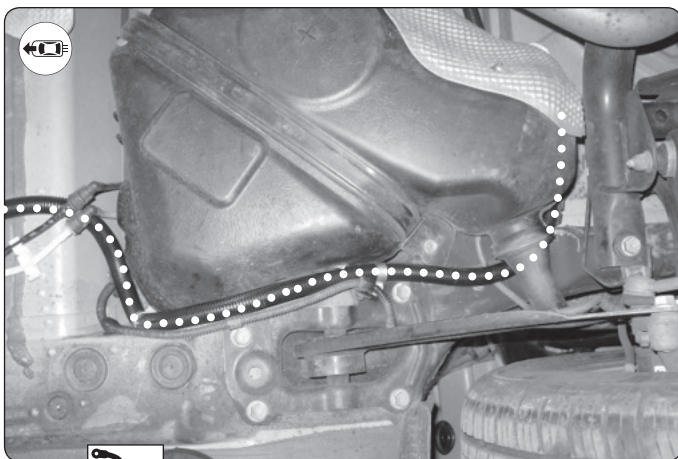

T1

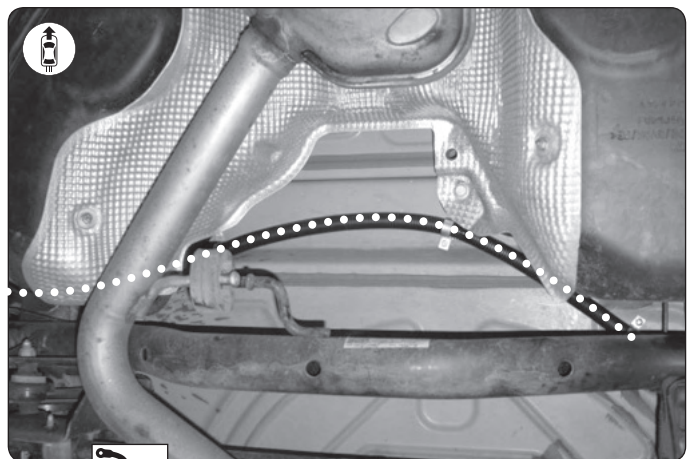

T1





T1



GUIDELINES AFTER THE ASSEMBLY (ENGLISH)

- After refuelling, please check all connections for the gas leading for eventual leakage(s).
- Check the LPG-system by using the diagnostic system (LDT) especially developed for the LPdi-system.

The possibilities of the programme are:

- You can read the hardware data, the programmed software, the LPE and the used injectors.
- You can ask for the electrical diagram/pin configuration of the placed LPE.
- You can read the error codes and reset the eventual error codes.
- The judgement of the parameters important for the functioning of the system.
- You can make visible and/or logging signals by using the monitor function.

- Please check that the R115-homologation sticker is placed in the vehicle (if delivered).
- If possible, please make a test ride with the vehicle.
- Check petrol system for (e)OBD trouble codes
- The Vialle LPdi-system is not adjustable and maintenance free.

RICHTLIJNEN NA INBOUW (NEDERLANDS)

- Controleer na het tanken alle gasvoerende verbindingen op eventuele lekkage(s)
- Controleer het LPG-systeem met behulp van het speciaal voor het LPdi-systeem ontwikkeld diagnose systeem (LDT)

De mogelijkheden van het programma zijn:

- De gegevens van de hardware, geprogrammeerde software, LPE en gebruikte injectoren kunnen uitlezen.
- Het elektrisch schema/penbezetting van de geplaatste LPE opvragen.
- De foutcodes uitlezen en het eventueel resetten van de foutcodes.
- Het beoordelen van de parameters die van belang zijn voor het functioneren van het systeem.
- Zichtbaar maken en/of loggen van signalen door middel van de monitorfunctie.

- Controleer of de R115-homologatiesticker in het voertuig is aangebracht (indien meegeleverd).
- Indien mogelijk, maak een testrit met het voertuig.
- Controleer of het benzine-systeem (e)OBD foutcodes bevat
- Het Vialle LPdi-systeem is niet afstelbaar en onderhoudsvrij.

RICHTLINIEN NACH EINBAU (DEUTSCH)

- Nach dem Tanken alle gastransportierende Verbindungen auf eventuelle Leckagen prüfen
- Prüfen Sie mit Hilfe des besonders für das LPdi-System entwickelte Diagnosesystem (LDT), das Steuergerät(Gasanlage)-System

Die Möglichkeiten des Programms sind:

- Die Daten der Hardware, programmierte Software, Steuersystem (Gasanlage) und benutzte Injektoren lesen können.
- Der Schaltplan/Stiftbelegung des positionierten Steuergeräts (Gasanlage) anfordern.
- Die Fehlercodes lesen und eventuell neu setzen der Fehlercodes .
- Die Beurteilung der Parameter die für das Funktionieren des Systems wichtig sind.
- Mittels der Monitorfunktion, sichtbar machen und/oder einloggen der Signale.

- Prüfen Sie ob der R115-Homologationsaufkleber ins Fahrzeug angebracht wurde (falls mitgeliefert).
- Machen Sie, wenn das möglich ist, mit dem Fahrzeug eine Probefahrt.
- Prüfen Sie ob das (e)OBD benzinsystem fehlercodes enthält
- Das Vialle LPdi-System ist nicht einstellbar und wartungsfrei.

INSTRUCTIONS APRÈS LE MONTAGE (FRANCAIS)

- Après la prise de l'essence, contrôlez toutes les connexions pour la conduite de gaz en cas d'éventuelles fuites.
- Contrôlez le système GPL avec l'aide du système de diagnostique (LDT) spécialement développé pour le système LPdi

Les possibilités du programme sont :

- On peut lire les données du hardware, le software programmé, le LPE et les injecteurs employés.
- On peut demander le schéma électrique/brochage du LPE monté.
- On peut lire les codes des erreurs et, éventuellement, remettre à zéro les codes des erreurs.
- Le jugement des paramètres importants pour le fonctionnement du système.
- On peut rendre visible et/ou carotter des signaux au moyen de la fonction de monitoring.

- Contrôlez si l'autocollant de l'homologation R115 est placé dans la voiture (si livré).
- Si possible, faire une promenade d'essai avec la voiture.
- Contrôlez si le système d'essence (e)OBD contient des codes de défaut
- Le système LPdi de Vialle n'est pas réglage et nécessitant de maintenance.

